

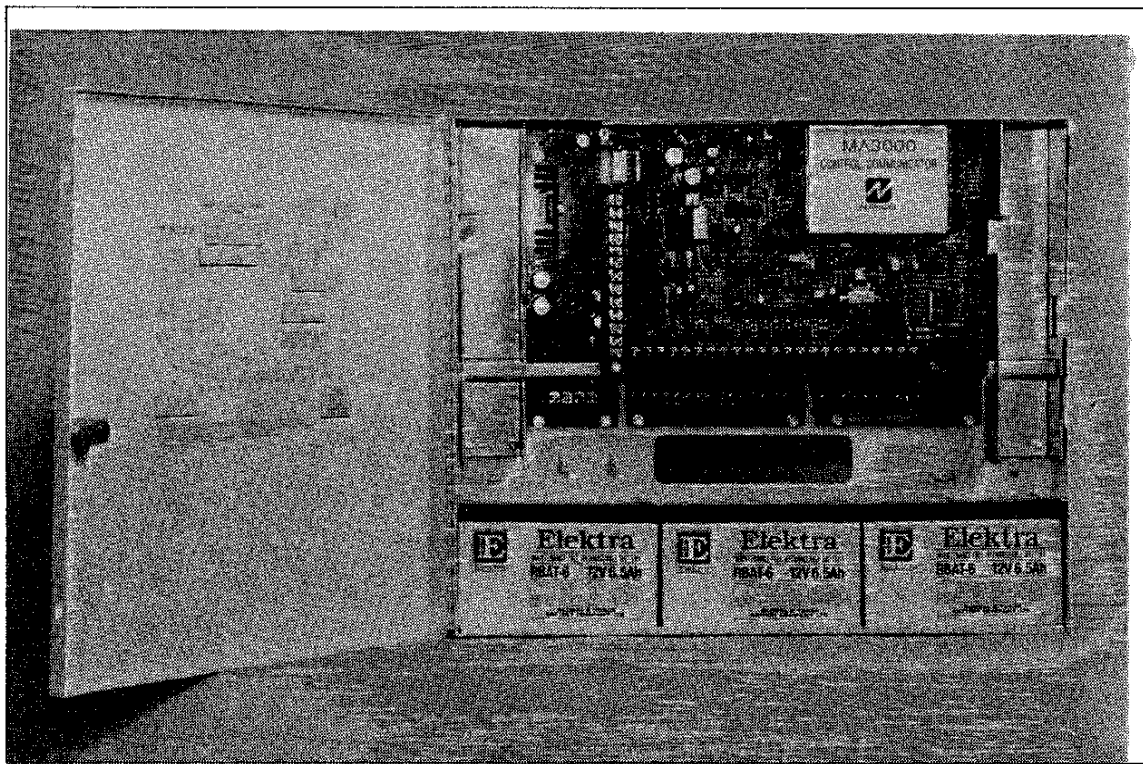

## INSTALLATION INSTRUCTIONS

### MAGNUM ALERT 3000 SERIES CONTROL PANEL/COMMUNICATOR



**UL Listed**

*RP3000LCD & CF3000LCD KEYPAD INSTRUCTIONS INCLUDED.*

*SEE PAGE 6 FOR A SUMMARY OF CHANGES FROM PREVIOUS EDITION.*

*(Also refer to Keypad Programming Workbook WI641.)*

**NOTE: THESE INSTALLATION INSTRUCTIONS ARE INTENDED AND WRITTEN FOR THE PROFESSIONAL INSTALLER HAVING SUITABLE EXPERIENCE AND INSTALLATION EQUIPMENT.**

## TABLE OF CONTENTS

<i>Section</i>	<i>Page</i>	<i>Section</i>	<i>Page</i>
<b>1. INTRODUCTION</b> . . . . .	<b>3</b>	ARMING & DISARMING THE SYSTEM . . . . .	13
GENERAL DESCRIPTION . . . . .	3	BYPASSING ZONES . . . . .	15
FEATURES . . . . .	3	DISABLING FIRE ZONES . . . . .	15
SPECIFICATIONS . . . . .	4	ALARM INDICATION . . . . .	15
ORDERING INFORMATION . . . . .	4	RP3000LCD FUNCTION MODE . . . . .	15
UL LISTINGS . . . . .	5	PRINTER PORT . . . . .	19
COMPATIBLE UL LISTED DEVICES . . . . .	5	RP3000LCD KEYPAD MESSAGES . . . . .	19
<b>2. INSTALLATION</b> . . . . .	<b>7</b>	<b>4. PROGRAMMING</b> . . . . .	<b>21</b>
MOUNTING . . . . .	7	DOWNLOADING FROM A COMPUTER . . . . .	21
WIRING . . . . .	7	KEYPAD PROGRAMMING . . . . .	21
TYPICAL FIRE INSTALLATION . . . . .	7	GENERAL PROGRAMMING STEPS . . . . .	22
COMMERCIAL-FIRE REQUIREMENTS . . . . .	8	<b>5. GLOSSARY</b> . . . . .	<b>23</b>
TYPICAL PARTITIONED INSTALLATION . . . . .	8	<b>6. APPENDIX</b> . . . . .	<b>37</b>
UL COMMERCIAL-BURGLARY INSTALLATIONS . . . . .	8	WIRING LEGEND . . . . .	37
GRADE-A LOCAL MERCANTILE INSTALLATIONS . . . . .	9	SYSTEM BLOCK DIAGRAM . . . . .	38
TESTING THE SYSTEM . . . . .	9	WIRING DIAGRAM . . . . .	39
<b>3. GETTING UP AND RUNNING</b> . . . . .	<b>10</b>	RP3000LCD KEYPAD FUNCTION & PROGRAM . . . . .	40
PRELIMINARY INFORMATION . . . . .	10	MODES . . . . .	40
POWER UP/PANEL CONFIGURATION . . . . .	10	FUNCTIONAL DIAGRAM, KEYPAD CONFIGURATION . . . . .	41
CONFIGURING THE KEYPADS . . . . .	11	MODES . . . . .	41
USER KEYPAD PROGRAMMING . . . . .	12	KEYPAD OPERATION, PROGRAM MODES . . . . .	42

*INDEX STARTS ON PAGE 44.*

**Napco Security Systems, Inc.**  
**333 Bayview Avenue**  
**Amityville, New York 11701**  
 For Sales and Repairs, call toll free: (800) 645-9445  
 For direct line to Technical Service, call toll free: (800) 645-9440

# 1. INTRODUCTION

## GENERAL DESCRIPTION

The Magnum Alert 3000 Series are state-of-the-art microcomputer-based commercial fire and burglary alarm control panels of modular design. Integrally 8-zone panels, they will support up to 96 zones with the use of optional zone expansion modules (EZM3000 series) and/or RP3000LCD Keypads. Each system includes an integral digital communicator and a 50VA power transformer.

The control panel features programmable area partitioning. That is, the system may be divided into up to eight discrete multiple-zone areas, each allowing access by only those users programmed for their respective area.

Opening Suppression and Closing Suppression, available through Napco Quickloader software, suppress reporting within programmed "windows". Conversely, Exception Reporting can report "fail to close" when the panel is not armed within programmed intervals and/or "fail to open" if the panel is not disarmed within programmed intervals. Furthermore, the panel can be programmed to automatically arm or disarm any area at any time. A log containing up to 800 events (accessible through Quickloader™ software or from the keypad) monitors control-panel activity referenced to a precision real-time clock. A detailed event history may be displayed at the computer, with an abbreviated display available at the keypad. A printout of the detailed report may be obtained if a printer is connected to the PRINTER OUT port J1 at the panel.

Keypads feature a liquid-crystal display for English-language messages. In normal daily use, the LCD is used for zone identification and status messages. Conventional LEDs and a sounder are also provided for annunciation.

Data may be quickly and easily downloaded to the control panel using a PC-compatible computer with Napco's PCD3000 Quickloader software and PCI2000 computer interface. Or, the panel may be programmed in its secondary mode of operation by the keypad. In the programming modes (there are two: *Dealer* and *User*), the LCD shows memory address, data value, programming prompts, and the alphanumeric characters required for entering up to 96 user codes and custom zone descriptions.

**Note:** Failure to install and program as described in this manual for UL-listed systems voids the listing mark of Underwriters Laboratories, Inc.

Commercial Burglary versions require that the H1518 enclosure be equipped with reinforcement brackets (Model CB1518KIT) for increased tamper resistance and with tamper switches for tamper protection. The CF5530 Fire Module is required for commercial fire installations.

## FEATURES

### Control Panel Features

- Fight end-of-line-resistor burglary zones programmable for Area, Exit/Entry Delay, Interior, Follower, Day Zone, Chime, Fire options, Sensor Watch, Swinger Shutdown and a variety of other features.
- Supports up to 96 zones with optional zone-expansion modules and 4-zone keypads.
- Supports up to 96 individually coded users, each with a programmable authority level.

- Supports up to 64 relay outputs.
- Supports three keypad panics: Fire, Police & Auxiliary
- Supports up to eight area partitions.
- Supports up to eight separate access stations by up to 96 users.
- English-language prompts & system status messages.
- User-customized zone descriptions, reprogrammable as required.
  - Commercial fire options.
- Supports 2-wire and 4-wire smoke detectors.
- Reports alarms, restores and troubles by zone.
- 250 Event Schedule
- 800 Event Log.
- Overview Mode permits monitoring and control of total system.
- Guard-Tour programmable for start time, tour length, and check points.
- Two programmable entry delay times.
- Two Interior-Zone groups.
- Dynamic battery test removes battery from the charging circuit for test under load.
- Chime by zone; programmable duration.
- Non-volatile RAM retains memory during power losses.
- Battery disconnect circuit prevents damage due to deep discharging.
- All functions Quickloader programmable.
- Printer output for hardcopies of event logs.
- Exclusive V.A.L.I.D.™ feature (Verifying Automatic Line-Integrity Diagnostic) reduces false alarms due to changes in line resistance.

### Communicator Features

- Compatible with all major receiver formats, including BFSK, 4/2, Modem 2, SIA, 4/3/1, 4 + 2 Express and Point ID.
- Rotary dial and TouchTone™ with Rotary backup.
- Three 20-digit telephone numbers.
- Backup Reporting; Double Reporting; Split Reporting.
- 96 User Codes with Opening/Closing Reporting by user.
- Ac Failure Reporting with programmable report delay.
- Supervised telephone lines with programmable test times.
- Pager capability.

### Keypad Features

- English-language LCD display; LED and sounder annunciators.
- Supports up to 15 4-wire keypads.
- Access only (RP3000LCD only).
- Provisions for fire, police and auxiliary panic alarms.
- Integral 4-zone EZM included in each keypad (RP3000LCD only).
- Communicator Test to Central facilitates testing; Locate, Fault-Find and EZM-Locate diagnostics simplify troubleshooting.
- PGM output (RP3000LCD only).

## SPECIFICATIONS

### MA3000

Operating Temperature: 0–49°C (32–120°F)

Input Power: 16.5Vac via Class 2 Plug-In TRF11 40VA Transformer or optional TRF14 50VA Transformer

Loop Voltage: 10–13Vdc

Loop Current: 2.5mA with 2.2kΩ end-of-line resistor (Model EOL2.2K); 5mA for 2-wire smoke-detector zones

Loop Resistance: 300Ω max.; 50Ω for 2-wire smoke-detector zones

Relay Outputs (Burglary; Fire; Reset; Aux): Wet, 12Vdc, 1.2A max.; Dry (cut related jumper for dry contacts; see *Wiring Diagram*), SPDT contacts 24Vdc, 2A, 0.6 Power Factor

Auxiliary Power Output: 12Vdc regulated\*

Remote Power Output: 12Vdc regulated\* (for keypads)

Combined Standby Current: (Remote EZM Power + Auxiliary Output):

Household Burg/Fire & Commercial Burg: with TRF11 40VA Transformer, 550mA with RBAT4 Battery; with TRF14 50VA Transformer, 0.9A with RBAT6 Battery or 1.1A with 2-RBAT4 Batteries.

Commercial Fire: with TRF14 50VA Transformer, 0.5A with 3 RBAT6 Batteries or 0.28A with 2 RBAT6 Batteries at max. bell output 1.2A (Requires PS3000 for 2.0A Bells)

EZM Module:

EZM3008: Input, 50mA (not including PGM output)

PGM Output: 5mA, 12V Special Application

Keypad Current:

RP3000LCD: 100mA; 35mA if backlighting is disabled (cut W1, W2 & W3)

PGM Output: 5mA, 12V Special Application

CF3000LCD: 100mA; 35mA if backlighting is disabled (cut W1, W2 & W3)

Maximum Number of Keypads: 15

Maximum Wiring Length for each run (#22AWG): 1000' divided by total number of keypads and EZMs on run

Standby Time: *Residential Fire/Burglary & Commercial Burglary*, 4 hours minimum; *Commercial Fire*, 24 hours

Keypad Dimensions: 4<sup>3</sup>/<sub>8</sub>" x 5<sup>7</sup>/<sub>8</sub>" x 1<sup>1</sup>/<sub>16</sub>" (HWD); 11.1cm x 14.9cm x 2.7cm (HWD)

\*Special application if PS3000 or BDH Battery Diode Bypass Harness is not used.

### PS3000 Power Supply (Optional)

Input Power: 18Vac with TRF15 (100VA Transformer with Housing)

Output: 12Vdc 4A max (including panel power) Combined Standby & Alarm, 12Vdc at 2.75A max. total; Alarm, 12Vdc at 4A max.; requires 3-RBAT6 Batteries

### CF5530 2-LINE COMMUNICATOR/BELL MODULE

Telephone Lines: Provides secondary supervised telephone line

Supervised Bell: Provides 12Vdc to bell(s), 2A max., 0.6 Power Factor; displays/reports bell trouble if circuit is open or shorted

Fire Keypad: Comm Bus #2 provides independent interface for supervised fire keypad and/or EZMs

Aux. Relay 1, Aux. Relay 2: Additional dry relays programmable for alarms or fire troubles.

Watchdog Sounder: Activates to indicate keypad failure

or panel failure.

## ORDERING INFORMATION

### System Components

**MA3000:** Commercial/Residential UL-Listed Burg and Fire Control Panel with 32-character RP3000LCD (12 Zones) and a 50VA Transformer.

**RP3000LCD:** 32-Character LCD Burg and Fire Keypad with 4 EOL Zones.

### Optional Accessories and Peripherals

**H1214:** Large Box and Lock, 12"x14"x3<sup>1</sup>/<sub>2</sub>" (HxWxD) (Not for Commercial Fire)

**H1518:** Extra Large Box and Lock, 17"x18"x3<sup>1</sup>/<sub>2</sub>" (HxWxD)

**CF1518:** As above, red (for use where required for Commercial Fire)

**CB1518KIT:** Mercantile Attack-Resistant Kit, includes bars and tamper switches (for H1518 or CF1518 Housing)

**EZM3004:** 4-Zone EZM Expansion Zone Module

**EZM3008:** 8-Zone EZM Expansion Zone Module

**RB3008:** "Octal" Relay Board (for mounting inside H1518 or CF1518)

**RM3008:** "Octal" Relay Module (in enclosure)

**CF5530:** Dual Phone-Line Switcher with signal-circuit supervision; 2nd remote bus; 2 aux. relays; watchdog sounder (conforms to NFPA 71 & 72 standards)

**CF3000LCD:** Dedicated Commercial Fire Keypad (red)

**M278:**\* Line-Reversal Module

**PS3000:** Auxiliary 4A Power-Supply

**PS3002:** Power-Supply Module, 13.2Vdc, 1.9A (Not for Commercial Fire use)

**EOL130:** 2-Wire Fire Zone Resistor, 130Ω, 3W

**EOL2.2K:** End-of-Line Resistor Assy., 2.2kΩ, for Fire Circuit

**FT2200:** End-of-Line Relay/Resistor Supervisory Module

**RBAT4:** Rechargeable Battery, 12Vdc, 4AH

**RBAT6:** Rechargeable Battery, 12Vdc, 6AH

**RBATH1:** Dual Battery Harness

**TPS2:** Tamper Switches, set of 2

**TH1:** Transformer Housing

**TRF11:** Transformer, 16Vac/40VA, Class 2 (Not for Commercial Fire use)

**TRF14:** Transformer, 16Vac/50VA, Class 2

**TRF15:** Transformer, 16Vac/100VA, Class 2, with TH1 Housing

**BDH:** Battery Diode Bypass Harness for Commercial Fire using TRF14

**WI 1-Wire Assembly with Lug Connector, 20"**

**MAV-15:** Two-Way Voice/Listen-In Module

**PCD3000:** Downloading Software for IBM PC-Compatible

**PCI2000/3000:** Software with Interface for IBM PC-Compatible Computer

**PCBL:** Printer Cable Adaptor

**OI146:** Instruction Manual, MA3000

**OI167:** Instruction Manual, RP3000LCD

**WI641:** Keypad Programming Workbook

\*Not tested by UL.

**UL LISTINGS**

**MA3000:** Household Burglary Alarm Control Unit; Household Fire Warning System Control Unit.  
**MA3000 with H1518 or CF1518 Enclosure and CB1518KIT (with or without PS3000):** Police Station Connected/Local/Central Station Burglary Alarm Control Unit.  
**MA3000 with CF5530 and PS3000:** Control Unit System Suitable for Non-Coded Local and Central Station. Suitable for Manual, Waterflow and Sprinkler Supervisory Type Service.

**COMPATIBLE UL-LISTED DEVICES**

**Bells:**

Ademco AD8-12\*; AD10-12\*  
 Amseco MBL-8/12V\*; MBL-10/12V\*  
 Wheelock 46T-G4-12-R\*\*; 46T-G6-12-R; 46T-G10-12-R  
 Hochiki America AL-VB-1012\*\*,\*\*\*; AL-MB-612\*\*,\*\*\*  
*\*Burglary Alarm Sounding Device; not polarized (not to be connected to CF5530).*  
*\*\*Not for Household Fire applications (< 85dB at 10')*  
*\*\*\*These devices require that the PS3000 or BDH Battery Diode Bypass Harness be installed.*

**Grade-A Bell:**

Ademco AB-12\* Bell in Box  
*\* Burglary Alarm Sounding Device; not polarized (not to be connected to CF5530).*

**Horns:**

Wheelock 34T-12-R  
 Faraday 6120-0-0-12-DC\*\* \*\*\*  
 Hochiki America AL-FH-12M\*\*,\*\*\*  
*\*\*Not for Household Fire applications (< 85dB at 10')*  
*\*\*\*These devices require that the PS3000 or BDH Battery Diode Bypass Harness be installed.*

**Strobe/Horns:**

Wheelock 7002T-12-W-FR; 7001T-12-W-FR; V7001T-12-W FR

**Electronic Signals:**

Wheelock ES-BH2-R; ES-DL2-R; ES-EL2-R

**Electronic Signal/Strobes:**

Wheelock ES-BH2-WH-12DC-HF-R; ES-DL2-WS-12DC-VF-R; ES-EL2-WS-12DC-HF-R

**Bell/Strobes:**

Wheelock 46T-G6-12-WS-12-HF-R; 46T-G10-12-WS-12-HF-R

**Smoke Detectors, 2-Wire:**

System Sensor (BRK) 1400; 2400; 2400TH, each with self-contained base; 1451; 2451; 2451TH, each with B401B Base  
 Voltage Rating: 8.5-13.3Vdc  
 Maximum Number of Detectors: 10  
 Detector Identifier: A (A11)  
 Base Identifier: A (for 1451, 2451, 2451TH Detectors)  
 Zone Identifier: MA3000A (MA3000 without PS3000); MA3000B (MA3000 with PS3000)

**REQUIRED EQUIPMENT FOR UL COMPLIANCE**

	BURGLARY, CENTRAL STATION POLICE STATION CONNECTED, LOCAL	COMMERCIAL FIRE LOCAL, CENTRAL STATION	RESIDENTIAL FIRE/BURGLARY
MA3000 BOARD	REQUIRED	REQUIRED	REQUIRED
RB3008	OPTIONAL	OPTIONAL	OPTIONAL <sup>(1)</sup>
RM3008	OPTIONAL	OPTIONAL	OPTIONAL
CF5530	OPTIONAL	REQUIRED	OPTIONAL <sup>(1)(5)</sup>
PS3000	OPTIONAL	REQUIRES EITHER PS3000 & TRF15 OR BDH & TRF14	OPTIONAL
BDH <sup>(2)</sup>	OPTIONAL		OPTIONAL
RP3000LCD	REQUIRED	REQUIRES EITHER RP3000LCD OR CF3000LCD	REQUIRED
CF3000LCD	NOT APPLICABLE		OPTIONAL
EZM3004	OPTIONAL	OPTIONAL	OPTIONAL
EZM3008	OPTIONAL	OPTIONAL	OPTIONAL
H1518	REQUIRED	REQUIRED	REQUIRES H1518 OR H1214
CF1518	NOT APPLICABLE	OPTIONAL	OPTIONAL
H1214	DO NOT USE	DO NOT USE	REQUIRES H1518 OR H1214
CB1518KIT	REQUIRED	OPTIONAL	OPTIONAL
TRF11	REQUIRES TRF11, TRF14 OR TRF15	DO NOT USE	REQUIRES TRF11, TRF14 OR TRF15
TRF14		REQUIRES EITHER TRF14 OR TRF15	
TRF15 <sup>(3)</sup>			
EOL2.2K	NOT APPLICABLE	REQUIRED	REQUIRED
EOL130 <sup>(4)</sup>	1 REQUIRED FOR EACH 2-WIRE SMOKE ZONE		
RBATH1	OPTIONAL	2 REQUIRED	OPTIONAL
RBAT4	REQUIRES EITHER RBAT4 OR RBAT6	DO NOT USE	REQUIRES EITHER RBAT4 OR RBAT6
RBAT6		3 REQUIRED	

**NOTES:** (1) Optional only if H1518 is used. (2) See Compatible UL-Listed Devices, Note \*\*\*. (3) May only be used with the PS3000 Power Supply Module. (4) Two supplied with each panel; for Zones 1-8 only. (5) Required if an EZM Module is used to monitor fire.

**Smoke Detectors, 4-Wire:**

BRK 2312/24T\*; 1412\*; 1412TH\*; 2412TH\*  
ESL 445AT, 445C\*, 445CT\*, 445CR\*, 445CRT\*  
Gentex 812\*, 812T\*, 812P\*, 812PT\*, 812PH\*; 8120\*,  
8120T\*, 8120P\*, 8120PT\*, 8120PH\*  
Hochiki America SLG-12\* with YBC-RL4-RA Base

*Subtract total smoke-detector alarm current from available standby current.*

**Note:** Any normally-open devices that do not require power from the control panel, such as pull stations, waterflow and thermostats may be used if acceptable to the Authority Having Jurisdiction.

*\*Requires PS3000 Power Supply or BDH Harness.*

**NOTES**

**CHANGES FROM PREVIOUS EDITION**

The following changes have been made to this edition.

- **Page 2:** New direct-line toll-free number added for Technical Service.
- **Page 4:** *SPECIFICATIONS*, Commercial Fire Combined Standby Current revised to include 2 RBAT6s.  
*ORDERING INFORMATION*, MAV-15 added.
- **Page 39:** *WIRING DIAGRAM*, Transformer/Battery Chart (Commercial Fire) and Note 4 revised.

## 2. INSTALLATION

**Note:** This equipment generates and uses radio-frequency energy. If not installed using conventional installation practices for rf devices, it may cause interference to radio and television reception. It has been tested and found to comply with the limits for a Class A computing device pursuant to Subpart B of Part 15 of FCC Rules, which are designed to provide reasonable protection against such interference. However, there is no guarantee that interference will not occur in a particular installation. If it has been found to cause interference to radio or television reception, which can be determined by removing and reapplying ac and battery power to the equipment, the installer should try to correct the interference by one or more of the following measures: reorient the receiving antenna; connect the power transformer to a different outlet so that the control panel and receiver are on different branch circuits; relocate the control panel with respect to the receiver.

### MOUNTING

#### Control Panel

For flexibility, the control panel is furnished without an enclosure. Select either the H1214, H1518 or CF1518 Housing (see *ORDERING INFORMATION* for dimensions) to suit the application. Choose a mounting location accessible to (a) a continuously-powered ac source, (b) a cold-water-pipe ground ideally no further away than 10 feet, and (c) telephone lines (keep telephone wiring away from bell/horn wires). Remove appropriate knockouts for cables. Place the control panel at a convenient viewing height and mark the mounting holes. Install the control-panel board in accordance with the instructions affixed to the back wall of the housing.

**Grounding.** Connect the control-panel grounding screw to a metal cold-water pipe. Do not use a gas pipe, plastic pipe or ac ground connections. Use at least 16-gauge wire. Make the run as short and direct as possible, without any sharp bends in the wire.

**Tamper Switches.** Tamper switches may be installed to prevent opening of the control-panel door or removal of the cabinet from the wall. Ideally, tamper switches should be connected to a zone that is active at all times, thus it may be necessary to program that zone for 24-hour protection. When used on a normally-open zone, normally-closed tamper switches (open when set) should be wired in parallel. On a normally-closed zone, install Napco TPS-2 normally-open tamper switches (closed when set) in series.

There are two places in the cabinet to mount tamper switches: (1) To prevent cabinet removal from the wall, there are three mounting holes on the left side of the cabinet, another hole on the back that allows the switch button to contact the wall. (2) To prevent opening the cabinet door, there are three mounting holes on the right side of the cabinet. When mounted, the switch button should contact the inside of the door. Be sure to alert the user that opening the enclosure door will cause a tamper alarm. **Note:** Each Napco tamper switch is furnished with three machine screws for mounting, and a single self-tapping screw. The sole purpose of the self-tapping screw is to tap the holes for the machine screws. It is then removed and may be discarded.

#### Keypad

A keypad should be located near each exit/entry door. The keypad features a handy pull-up reference label. Before mounting the keypad onto the wall, push the Sliding Label Plate (with label and felt backing affixed and handle facing forward) down the guides at the rear of the keypad until it snaps into place. Once installed, the Sliding Label Plate cannot be removed without first removing the keypad from the wall. **Note:** (1) The keypad fire and panic keys should not be considered a substitute for a listed manual initiating device (such as a pull box). (2) Each RP3000LCD includes provisions for four additional zones. See *ADDING EXPANSION ZONES*.

If installing onto a double-gang box, insert mounting screws through the two vertical elongated holes on the left side of the case and into the box. If the box is visible when viewed from the front, adjust the keypad vertically and tighten the screws. Then, using hardware suitable for the mounting surface, add one or two screws at the right side of the keypad case directly into the wall to ensure a secure installation. **Note:** Do not overtighten the screws! Uneven walls may cause the keypad case to distort.

### WIRING

Wire keypad(s), zones, expansion zone modules and output devices as shown on the Wiring Diagram. Note that the Wiring Diagram contains important information not available elsewhere in this manual. *Caution:* Do not run telephone wiring near speaker wires; do not run keypad wiring with loop wiring.

#### Adding Expansion Zones

MA3000-Series control panels will handle up to 8 zones, however this number may be increased to up to 96 programmable zones using optional expansion zone modules (EZMs). Two models are available: the EZM3004 provides 4 additional zones; the EZM3008, 8 additional zones. (Refer to the instructions furnished with the EZM modules for expansion-zone wiring and system connection to panel.) Furthermore, each RP3000LCD can provide up to four additional zones and, in that regard, should be treated as a four-zone expansion module for the purposes of designing and configuring the system.

**Note:** Subtract total EZM current, as well as keypad current, from available standby current. Refer to *Ordering Information: Optional Accessories and Peripherals* for available power transformers.

#### TYPICAL RESIDENTIAL FIRE INSTALLATION (Where permitted by local codes)

At least one smoke detector should be installed directly outside each sleeping area. If there is more than one floor, additional smoke detectors should be installed on each level, including the basement. The living-area and basement smoke detectors should be installed near the stairway of the next upper level.

For increased protection, additional detectors should be installed in areas other than those required, such as the dining room, bedrooms, utility room, furnace room, and hallways. Heat detectors, rather than smoke detectors, are recommended in kitchens, attics, and garages due to conditions that may result in false alarms and improper operation. Large areas and areas with partitions, ceiling beams.

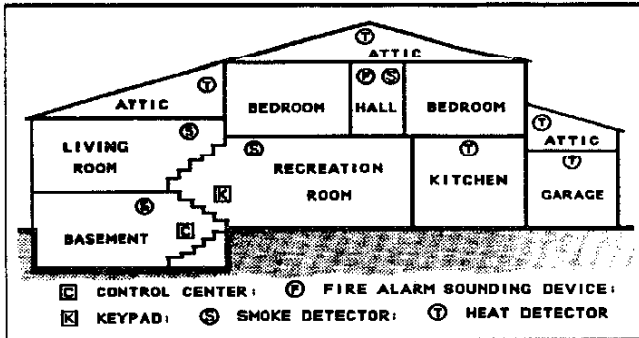

**Typical fire installation.**

doorways, and open joists will require additional detectors.

Refer to NFPA Standard No. 74 (National Fire Protection Association, Batterymarch Park, Quincy, MA 02269) for additional information, including proper mounting of detectors.

### COMMERCIAL FIRE INSTALLATION REQUIREMENTS

#### General

The panel must be programmed through the PCD3000 and the account must be selected as either a "UL LOCAL COMMERCIAL FIRE" or "UL REPORTING COMMERCIAL FIRE". The PCD3000 will not allow a commercial fire account to be downloaded if the program does not meet the minimum requirements of a UL Commercial Fire panel.

The panel must be located so that those having authority for the fire system can hear the panel sounder (on the CF5530 module). The panel sounder will activate during any keypad failure or if the panel becomes non-functional.

In a partitioned system all Fire Zones must be in one area.

Once the panel is programmed with the account, the panel program may be viewed through the keypad, but it cannot be altered. Only through the PCD3000 may the program be altered.

If the panel has been programmed as local Commercial Fire, a remote download may only be site-initiated using the "DOWNLOAD" function.

If the panel has been programmed as reporting Commercial Fire, any local or remote download from the PCD3000 will cause the panel to report a "program change" to the central station. A Commercial-Fire panel status may be viewed remotely, but fire alarms cannot be silenced, acknowledged or reset remotely.

A complete functional checkout of the system is required following any programming or reprogramming.

To determine if the panel is Commercial Fire, enter the Dealer Program Mode and view Location 0000. If the panel is a UL local Commercial Fire panel, Location 0000 will display "• F". If the panel is a UL central station Commercial Fire panel, Location 0000 will display "F •". Location 0000 can only be altered through the PCD3000.

#### Required Accessory Devices for Commercial Fire

The following accessories are required in Commercial Fire systems:

1. CF5530 Dual Phone-Line Switcher.
2. Either TRF15 Transformer with Housing and PS3000 Auxiliary Power Supply or TRF14 Transformer and BDH Battery Diode Bypass Harness.
3. At least 1 RP3000LCD or CF30000LCD Keypad.

#### 4. H1518 or CF1518 Housing.

#### TYPICAL PARTITIONED INSTALLATION

Described and illustrated here are an example of a partitioned system with common-area protection of the control-panel room. This system meets UL requirements for a partitioned installation.

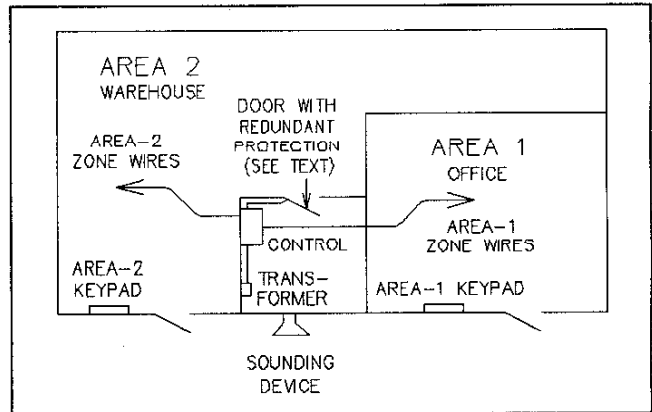

**Typical partitioned installation.**

- In Commercial Fire applications, all Fire Zones must be in one area.
- All areas must be owned and managed by the same person(s).
- All areas must be part of one building at one street address.
- The control panel and all wiring protecting each partitioned area must be confined to the respective area and may not encroach upon any other area. This requires that the control panel room have redundant protection; that is (a) multiple sets of door contacts, each wired to a separate zone and (b) one of those zones programmed for each area. In order to gain access to this protected area without causing an alarm, all partitions must be disarmed. In lieu of redundant protection, 24-Hour Zones may be used. Any zone protecting the control panel and transformer may not be programmed for bypass.
- The sounding device must be placed such that the bell test can be heard by all partitions. **Note:** NFPA 74 (Household Fire Warning Equipment) requires that a fire alarm audible device be installed indoors.
- The User Program Code is not to be given to anyone except the authority responsible for all partitions.

#### UL COMMERCIAL BURGLARY INSTALLATIONS

The MA3000 can be used as part of a UL Central Station Grade C, B, or A installation. Normally, a digital communicator is classified as Grade C and may be classified Grade B if used with the specified Grade-A Local bell and bell housing. A UL Central Station Grade-A installation requires the use of a Napco RB3008 Relay Board and Ademco 7600 Radio System. Refer to the installation instructions furnished with each component for respective installation requirements.

For a UL Commercial Grade-A Police Station Connection, refer to *GRADE-A LOCAL MERCANTILE INSTALLATIONS*, which follows. Use the M278 Line-Reversal Monitor to provide basic line security; refer to the instructions accompanying the M278 for other installation requirements.



## GRADE-A LOCAL MERCANTILE INSTALLATIONS

A Grade-A Local Mercantile installation must use at least a 6.0AH standby battery. Programming must include *Auto Bell Test on Arming*. *Trouble on Night Open* may not be programmed.

The minimum requirements for a listed Grade-A Local system include:

- Low-Battery Announcement.
- The H1518 or CF1518 Enclosure with CB1518KIT Attack-Resistant Kit.
- An Ademco AB-12 Bell and Box (12-volt).
- Program *Auto Bell Test on Arming*.
- a maximum Entrance and Exit Delay of 60 seconds.

## Interfacing to the Ademco 7600 Long-Range Wireless System

The RB3008 may be used to interface the MA3000 control panel to the Ademco 7621AD transmitter interface in order to meet UL Central Station Grade-A or Grade-B requirements by using a digital communicator combined with one-way wireless. (Normally, a digital communicator is Grade C, and may be Grade B if the specified Grade-A local bell is used.) Refer to the wiring diagram below, and to the instructions furnished with the Napco and Ademco equipment for further information concerning the DACT, listed compatible receiver and formats, Grade-A local bell and bell housing. *Enable Line-1 Fault Test* must be programmed.

## Central Station Grade-B Requirements.

Wiring between the Ademco 7621AD and the 7622 transmitter must be enclosed in rigid conduit when outside walls, or in flexible conduit when inside walls or above ceilings, for the entire length up to the transmitter room. The transmitter room must be protected by a UL listed intrusion detection unit that is connected to one of the input channels of the Ademco 7621AD. Relays must be programmed to trip the Ademco 7621AD for alarms on all protective circuits, including tampers, telco phone failure, 24-hour test timer, transmitter low battery and ac loss. (See FGD3000 Remote Relay Control screen.) One zone on the MA3000, programmed as a 24-Hour Zone, must supervise the radio.

## Central Station Grade-A Requirements.

In addition to Grade-B Requirements (above), one relay on the RB3008 must be programmed to trip the Ademco 7621AD when the telephone line fails. Daily openings and closings are required to be transmitted by the Napco panel along with the 24-hour DACT test signal and DACT trouble conditions.

## TESTING THE SYSTEM

After installation is completed, test the system as follows. Call the central station to inform them of the test. Initiate an alarm (preferably on a zone that activates a steady siren) and verify proper signalling. Then, call the central station to confirm their receipt of a good transmission.

Be sure to test all enabled keypad panics.

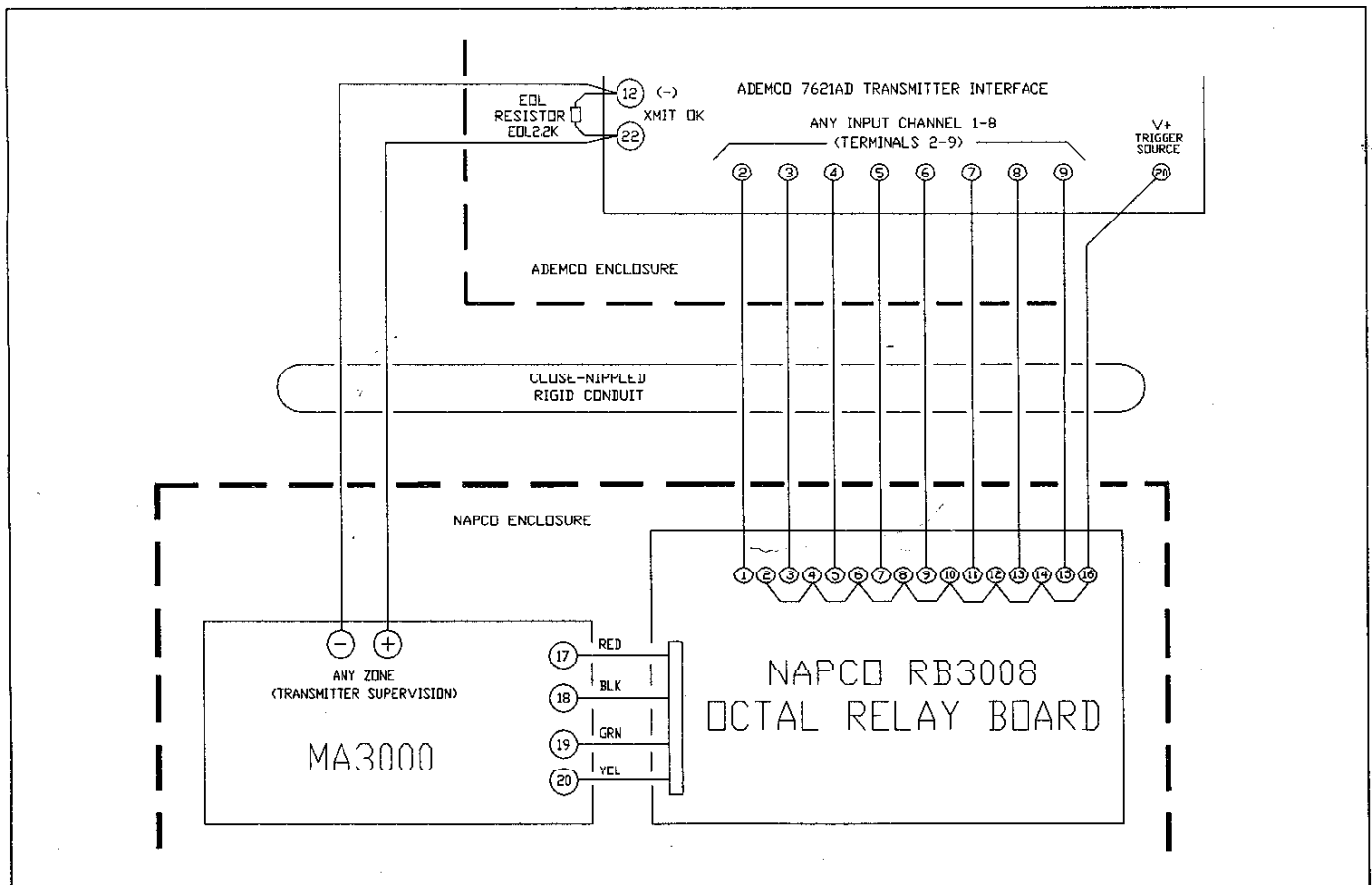

Interfacing to the Ademco 7600 Long-Range Wireless System.

### 3. GETTING UP AND RUNNING

This section will focus on starting the system after Installation is completed using both the RP3000LCD and CF3000LCD Keypads. References are made to keypad programming, which is covered in detail in *PROGRAMMING* (Section 4). (If there is more than one keypad in the system, *only Keypad No. 1 may be used for programming.*)

#### PRELIMINARY INFORMATION

Carefully read and note the following before proceeding:

1. Throughout this text, panel markings will be shown in upper-case letters (e.g., SAVE Button); button markings will be shown in bracketed upper-case letters (e.g., [ON/OFF] Button, and LCD displays will be shown in quotes, in upper-case letters (e.g. "SYSTEM READY").
2. The Master Security Code is printed on the micro can. Use this code to enter the Dealer Program Mode (to program a custom Dealer Program Code, if desired).
3. When entering or programming codes or locations, follow the numeric entry by the [ON/OFF] (SAVE) Button. The command will not be acknowledged, nor the program entered, until this button is pressed.
4. If the keypad is left in the Program Mode and unused for longer than 4 minutes, a steady tone will sound. Silence the sounder by pressing any button.

#### Available Keypads

Two types of keypads may be used with the MA3000: the RP3000LCD and the CF3000LCD. Each requires its own configuration procedure (see *CONFIGURING THE KEYPADS*).

**RP3000LCD.** The RP3000LCD is a combination fire/burglary/access keypad capable of supporting 4 EZM zones and a PGM output. At least 1 must be used in all burglary installations, and only 1 is required for a single-area combination Commercial Fire/Commercial Burglary installation.

**CF3000.** The CF3000LCD is a fire keypad, primarily used in partitioned Commercial Fire applications. It may also be used as the only keypad when there are only Fire Zones in the system, but the panel must be programmed through the PCD3000 before the keypads will operate (see *POWER-UP SEQUENCE*).

#### Keypad Assignment Programming

1. When the system is installed, each keypad must be assigned a keypad address (1-15). See *CONFIGURING THE KEYPADS*, which appears later in this section.
2. Each keypad (1-15) in the system must be designated a type (Burglary or Fire) and assigned to an Area (1-8). See Keypad Programming Workbook WI641: *KEYPAD AREA ASSIGNMENTS*. If a keypad is not programmed as a Fire ("CF") Keypad, it is assumed to be a Burglary ("RP") Keypad.
3. Each area in the system must be designated a Type ("BURC" or "FIRE"). See Keypad Programming Workbook WI641: *FIRE KEYPAD AREA*. If not programmed as a Fire Area, it is assumed to be a Burg Area.
4. All Burglary ("RP") Keypads must be assigned to BURG areas, even though those areas may contain Fire Zones.
5. All Fire ("CF") Keypads must be assigned to FIRE areas. All zones in a FIRE area should be restricted to Fire Zones.

#### POWER-UP/PANEL CONFIGURATION SEQUENCE

The MA3000 leaves the factory with no panel program and in a non-functional state. For the panel to operate, the installer must configure the panel as a Commercial Fire panel or as a non-Commercial Fire panel (Residential Fire/Burglary, Commercial Burglary).

#### Configuring the Panel using the PCD3000 Local Connection Before Panel Installation

1. Create a PCD3000 account with at least the following information: (a) Master Security Code (number on the top of the panel micro shield) in the <Subscriber Information> screen. (b) Panel Type in the <System Configuration> screen. (c) Preliminary or finished program.
2. Install the panel into the chosen housing (H1214, H1518 or CF1518).
3. Using the 6-conductor telephone wire supplied with the PCI3000, connect the panel to the PCI2000. Connect one end to "J3 LOCAL TO PANEL ONLY" on the PCI2000. Connect the other end to "J3" on the MA3000.
4. Using the <Local Communication> screen in the PCD3000, download the Panel Program, Zone Descriptions, and Schedule.
5. The panel should remain connected to the PCI3000 for at least 30 seconds to charge the memory-protect circuit.
6. Remove the 6-conductor telephone wire from the MA3000.
7. The panel is now configured and programmed, and can remain so for approximately 2 weeks without power. (Once installed, the panel can retain memory for months of extended power failure due to its advanced battery conservation circuitry.)

**Note:** If *Detect Ground Fault* is programmed, the panel may go into system trouble ground fault while it is connected to the PCI2000.

#### Configuring the Panel using the PCD3000 Remote Connection After Panel Installation

1. Create a PCD3000 account with at least the following information: (a) Master Security Code (number on the top of the panel micro shield) and Panel Phone Number in the <Subscriber Information> screen. (b) Panel Type in the <System Configuration> screen. (c) Preliminary or finished program.
2. At the site, install the system referring to the wiring diagram. **Note:** The telephone wiring must be correctly installed (see *Wiring Diagram*).
3. Connect ac power and battery. **Note:** The panel cannot be powered up from the battery alone.
4. The keypad(s) will display "SYSTEM TROUBLE / NO PANEL PROGRAM" and the keypad sounder will pulse.
5. Press [RESET]. The sounder(s) will silence, the keypad(s) will display "CHECK TROUBLE" and the "SYS TBL" reminder will be on.
6. At the PCD3000, select "Establish Callback" from the <Remote Connection> screen.
7. After the connection has been established, Download and Verify: Program, Zone Descriptions and Schedules.
8. Terminate Connection.
9. The panel is now configured and programmed.

#### Configuring the Panel as a Non-Commercial Fire

### Panel using the RP3000LCD

1. Referring the wiring diagram, connect zone and keypad wiring.
2. Connect ac power and battery. **Note:** The panel cannot be powered up from the battery alone.
3. Install one keypad on the system.
4. The keypad will display "SYSTEM TROUBLE / NO PANEL PROGRAM" and the keypad sounder will pulse.
5. Press [RESET]. The sounder will silence, the keypad will display "CHECK TROUBLE" and the "SYS TBL" reminder will be on.
6. Enter Master Security Code (on micro shield) and press [FUNCTION].
7. Press [FUNCTION] repeatedly until "ACTIVATE PROGRAM" displays.
8. Press [ON/OFF]. You are now in Program Mode 1.
9. Press [RESET]. You are now in Program Mode 2.
10. Wait until "ADDR = 0000DATA = ●●" appears.
11. Using the [1] and [2] buttons to move the cursor, and the [3] and [6] buttons to alter the address, change the screen to "ADDR = 3072DATA = ●●". Press [ON/OFF].
12. Press [RESET] to exit Program Mode 2. The panel is now programmed with the burglary default program and the system trouble, "NO PANEL PROGRAM" should be cleared.

### CONFIGURING THE KEYPADS

RP3000LCD and CF3000LCD keypads require different configuration procedures, as described in the following sections.

#### Configuring the RP3000LCD

Each RP3000LCD keypad must be configured with regard to

- keypad tactile beep (on/off)
- entry sounder (on/off)
- keypad address
- compatibility number
- EZM address
- zone response

To enter the Keypad Configuration Mode, move Jumper J5 (located to the left of the micro can) from Pins 1-2 (top two) to Pins 2-3 (bottom two). After about 15 seconds, the display will read "XX OUT OF SYSTEM". Press [1], [1], [1], [2], [3], [FUNCTION] and proceed as follows. (Repeat the following procedure for all keypads.)

**Keypad Tactile Beep.** Upon entering the Keypad Configuration Mode, "Keypad Beep ON" will be displayed, indicating that the tactile beep, which sounds when any button is pressed, is on. To turn off the tactile beep, press the [ON/OFF] Button (the [ON/OFF] Button will toggle the tactile beep on and off). Press the [FUNCTION] Button to continue or press [RESET] to exit.

**Entry Sounder.** To turn off the keypad sounder during entry time, press the [ON/OFF] Button (the [ON/OFF] Button will toggle the entry sounder on and off). Press the [FUNCTION] Button to continue or press [RESET] to exit.

**Keypad Address.** Up to 15 keypads may be connected to the panel. If more than one keypad is installed,

- each must be assigned its own unique keypad address (that is, no two keypads may be numbered alike);
- keypads must be numbered consecutively (that is, missing numbers are not permitted); and

- only Keypad No. 1 may be used for programming.

To assign the keypad number, proceed as follows:

1. Press the [FUNCTION] Button until "KP Address XX" is displayed.
2. Enter the assigned keypad number 01-15, then press the [ON/OFF] Button to save. A valid number will be acknowledged by a short beep; an invalid number will be rejected by a long beep.

**Note:** In multiple-keypad/multiple-area configurations, each keypad must be designated to an area. See *Keypad Area Assignments* in the Keypad Programming Workbook.

3. Press the [FUNCTION] Button to continue or press [RESET] to exit.

**Compatibility Number.** The compatibility number is a 4-digit security code that, if programmed into both the control panel and each keypad, dedicates the keypad to only that panel. That is, (a) similar keypads not having the correct compatibility number will not operate in the system and (b) a keypad may not be removed for use on a system with a different compatibility number. **Note:** If assigning compatibility numbers, record and store them in a safe place.

While the compatibility number may be changed, the old number must be known in order to program the new number. **Note:** If neither the control panel nor the keypad is given a compatibility number, both default to "0000" (thereby maintaining compatibility).

To program the compatibility number, press the [FUNCTION] Button until "New Compat#0000" is displayed. Enter the 4-digit compatibility number that is programmed into the panel. **Note:** If the keypad had been previously programmed for a compatibility number other than "0000", the display would read "Old Compat.# xxxx". Enter the existing number before attempting to change it.

**EZM Address.** The keypad's internal EZM (Expansion Zone Module) may be utilized to provide four additional wired zones. Whether used alone or in conjunction with optional EZM3000-series modules or other keypad EZMs, it must be assigned a unique address (or *Group* number, see Keypad Programming Workbook) similar to its keypad address. If no other EZMs are to be used, designate the keypad as Group "01" at the "EZM Address 00" display. In multiple-EZM systems, enter an assigned group number "01" through "22". (Each EZM must have a unique assigned group number, starting with "01" and proceeding consecutively.)

**Zone Response.** The normal loop response time of each keypad expansion zone is 750mS. However, the response time of any zone can be reduced to 50mS as follows.

1. Of the following, circle the number(s) in parentheses associated with the zone(s) to be changed: Zone 1 = (1); Zone 2 = (2); Zone 3 = (4); Zone 4 = (8).
2. Add up the circled numbers.
3. At the keypad, enter the sum as a two-digit number "01" through "15" on the display, then press the [ON/OFF] Button.

*Example.* Change Zones 2, 3 and 4 to 50mS response.

1. Circle the numbers for Zones 2, 3 and 4: (2), (4) and (8).
2. Add up the circled numbers: 2 + 4 + 8 = 14.
3. Enter "14" at the keypad, then press the [ON/OFF] Button.

Press [RESET] to exit the Keypad Configuration Mode

(display will read "01 OUT OF SYSTEM"). Then replace Jumper J5 across Pins 1–2 (top two pins).

### Configuring the CF3000LCD

Each CF3000LCD keypad must be configured with regard to

- keypad address
- compatibility number
- system configuration

To enter the Keypad Configuration Mode, move Jumper J5 (located to the left of the micro can) from Pins 1–2 (top two) to Pins 2–3 (bottom two). After about 15 seconds, the display will read "OUT OF SYSTEM". Press [1], [1], [1], [2], [3], [INFO] and proceed as follows. (Repeat the following procedure for all keypads.)

**Keypad Address.** Up to 15 keypads may be connected to the panel. If more than one keypad is installed,

- each must be assigned its own unique keypad address (that is, no two keypads may be numbered alike);
- keypads must be numbered consecutively (that is, missing numbers are not permitted); and
- only Keypad No. 1 may be used for programming.

To assign the keypad number, proceed as follows:

1. Press the [INFO] Button until "KP Address XX" is displayed.
2. Enter the assigned keypad number 01–15, then press the [SILENCE] Button to save. A valid number will be acknowledged by a short beep; an invalid number will be rejected by a long beep.

**Note:** In multiple-keypad/multiple-area configurations, each keypad must be designated to an area. See *Keypad Area Assignments* in the Keypad Programming Workbook (WI641).

3. Press the [INFO] Button to continue or press [RESET] to exit.

**Compatibility Number.** The compatibility number is a 4-digit security code that, if programmed into both the control panel and each keypad, dedicates the keypad to only that panel. That is, (a) similar keypads not having the correct compatibility number will not operate in the system and (b) a keypad may not be removed for use on a system with a different compatibility number. **Note:** If assigning compatibility numbers, record and store them in a safe place.

While the compatibility number may be changed, the old number must be known in order to program the new number. **Note:** If neither the control panel nor the keypad is given a compatibility number, both default to "0000" (thereby maintaining compatibility).

To program the compatibility number, press the [INFO] Button until "New Compat# 0000" is displayed. Enter the 4-digit compatibility number that is programmed into the panel. **Note:** If the keypad had been previously programmed for a compatibility number other than "0000", the display would read "Old Compat.# xxxx". Enter the existing number before attempting to change it.

**System Configuration.** To program the system configuration mode, press the [INFO] Button until "FireKP Conf00" is displayed. Program the two digits as follows:

- "00" – Code entry required for all functions.
- "02" – Annunciator keypad only. (Keypad can only silence its own sounder.)

### USER KEYPAD PROGRAMMING

After the panel and keypads have been configured as previously described, the keypad may be used for programming. Note, however, that

- only the main keypad (Keypad #1) may be used for programming;
- the Program Mode cannot be accessed while the communicator is transmitting except during the first three minutes after power-up;
- if a CF3000LCD is designated as Keypad #1, it must first be programmed as a "CF Keypad" using the PCD3000 Quickloader software; and
- if programmed as a Commercial-Fire panel, the program may be viewed but not altered at the keypad.

In the Program 1 Mode, the user can customize exit/entry times, codes and zone descriptions in the following sequence.

- Exit Time
- Entry Time 1
- Entry Time 2
- User Code 1–96 with associated Option(s), Authority Level Codes and Access Byte.
- Access Code
- Ambush Code
- Zone Description 1–96

1. Enter the Program Mode as follows: Enter a Level-3 User Code with *Program* option enabled (Burglary default code 1,2,3; see *User Codes, Authority Levels and Access Bytes*), then press the [FUNCTION] Button to enter the Function Mode. Press the [BYPASS] Button *twice* ("ACTIVATE PROGRAM", then press the [ON/OFF] Button to access the Program 1 Mode. (Also see *Program Code*.) The LCD will briefly read "PROGRAM1 #XXXX" (where "XXXX" denotes the panel and keypad software versions), and then "EXIT TIME (060)".

2. The keypad buttons now take on new functions: Keys [1] and [2] move the cursor left and right respectively within the display; Keys [3] and [6] scroll up and down, respectively, through numbers 0-9, the alphabet, etc. (depending on what is being programmed), as shown on the display.

3. The following buttons also take on new meanings in the Program 1 Mode:

- [INTERIOR] (NEXT) scrolls the display forward to the next line (hold down for fast forward).
- [INSTANT] (PRIOR) scrolls the display backward to the previous line (hold down for fast reverse).
- [0] (CLEAR) clears the number at the cursor.
- [ON/OFF] (SAVE) memorizes the programmed code, description, etc. **Note:** In Commercial Fire systems, any changes will revert to the original programmed values.

4. Pressing [RESET] terminates the Program 1 Mode.

**Exit/Entry Times.** Exit delay and entry delay establish the amount of time that is available on the Exit/Entry Zone after arming and before disarming, respectively, before the system will go into alarm. Two separate entry delays are available.

Entering the Program Mode will display "EXIT TIME (060)". Use all three digits to enter the exit time, in seconds, even if leading zeros are necessary. Thus, to program 30 seconds, enter "030"; to program 2 minutes, enter "120", etc. (Maximum programmable time is 255 seconds.)

Press the NEXT Button ([INTERIOR]) and repeat the above procedure to program ENTRY TIME1. Press the NEXT Button once again and similarly program ENTRY TIME2, if used.

**User Codes, Authority Levels and Access Bytes.** Up to 96 personal user codes, each with associated Option(s), Authority Level and Access Byte may be programmed at the keypad.

The first code entered "U01 123●●●-E3-●●" should replace the default (Level-3) code (1,2,3), which may not be selected as a user code. Enter up to six digits (a minimum of four digits is recommended) with a related Option Code and Authority Level. If *Remote Access* is selected for any user code, also program the Access Byte for applicable keypads 1 through 8. Refer to the Keypad Programming Workbook (supplied) for guidance in selecting options, authority levels and access byte. **Note:** (1) Do not attempt to enter any blank spaces in the code. When the code has been entered, press the SAVE Button ([ON/OFF]) to memorize it. (2) If an Access Byte is programmed for any code, that code will no longer function as an Arm/Disarm Code. See *Remote Access Code*.

To advance to the next user code (or to any other user code, for that matter), position the cursor over the displayed User Number, i.e., "01" using Keys [1] and [2] and change the User Number using Keys [3] and [6]. Repeat the User-Code programming procedure for the new user code. Advance to the next user code, as above, and repeat until all user codes have been programmed. **Note:** An attempt to program a code for User 97-99 or 00 will result in the message "(ERROR-XX)".

Each user should be assigned his own dissimilar code and should be cautioned against divulging his code to anyone else. Thus should it become necessary to remove a user from the system, that one code may be cancelled without affecting other codes, and that user would then be prevented from entry. **Note:** Napco's PCD3000 Quick-loader Software provides enabling and disabling User Codes at programmed times using the scheduling menus.

**Changing or Cancelling a Code.** To change any code, merely program over the existing code as previously described, then press the SAVE Button ([ON/OFF]). Similarly, to cancel a code, blank out each number of the code using the CLEAR Button [0], then press the SAVE Button ([ON/OFF]).

**Arm-Only Code.** An Arm-Only Code, selected in conjunction with Authority Level, may only be used to arm the system; it never has any disarm capability. This may be programmed as a one- or two-digit code for the purposes of quick arming.

**Service Code.** The Service Code is an Arm/Disarm Code that is easily activated when needed, and dormant at other times. Intended for the occasional or temporary user (maid, repairman, etc.) who would otherwise be denied access to the premises, it is programmed in conjunction with the Authority Level when programming User Codes. Refer to the Keypad Programming Workbook.

The Service Code is activated by arming with it; an "s" will appear in the display after the exit-delay countdown, indicating that the Service Code has been activated. It may then be used to arm and disarm just as any other User Code. However it will automatically be deactivated the next time any other User Code is entered to arm the system, and it will remain deactivated until it is once again used to arm. Thus, the Service Code can always *arm* the system, but can

only *disarm* if activated.

**Panel Access Code.** The Access Code is normally used to activate a door strike to remotely unlock a door. The Access Code is programmed as any other User Code (see *USER KEYPAD PROGRAMMING*) but without an accompanying Priority Level. **Caution:** Do not use the same code as any Arm/Disarm Code. **Note:** These systems have not been investigated by UL for compliance with UL294 (Access Control Systems).

**Remote Access Code (RP3000LCD only).** Any of the 96 User Codes may be converted to a *Remote Access Code* by programming the code's Access Byte (the last two digits of the code). Program the Access Byte for the applicable keypads 1 through 8, as indicated in the supplied Programming Workbook. Note that if the Access Byte is programmed, that User Code will function only as a Remote Access Code (*not* as an Arm/Disarm Code). Entering the code will cause a 5-second output on the PGM line with a pulsing sounder at the keypad and "\*\*ENTER NOW\*\*" displayed. **Note:** (1) RP3000LCD Keypads may be programmed for access only, eliminating their arm/disarm function (keypad will then normally display "\*ENTER CODE\*"). (2) Remote access may be logged into the event log by keypad.

**Ambush Code.** The Ambush Code is a one- or two-digit code entered by the user just prior to disarming, typically to cause a silent report to be sent to the central station. Thus, should the user be forced to disarm by an assailant, he can silently signal an emergency while appearing to be merely disarming the panel. (Check the glossary for programming required to enable this feature.) Program the Ambush Code as any User Code (see *USER KEYPAD PROGRAMMING*).

**Zone Descriptions.** Zone descriptions follow the Program Code in the normal programming sequence ("01-" will appear in the display). Refer to *USER KEYPAD PROGRAMMING*. Program the description, up to two lines, letter by letter. Keys [1] and [2] control the position of the cursor. Advancing the cursor beyond the end of the screen will cause the second line to display for programming. Key [0] will clear the entry at the cursor. When programming zone descriptions, Keys [3] and [6] will scroll not only through numbers 0-9, but through the alphabet and a series of punctuation marks and symbols as well. (Roughly note the order in which the letters, numbers and symbols are displayed so that you will be able to determine the proper direction to scroll, up or down, for fastest access. As familiarity improves, so will programming speed.) When the description has been entered and is satisfactory as displayed (e.g. "GARAGE"), press the SAVE Button ([ON/OFF]) to save it in memory.

To advance to the next zone (or to any other zone, for that matter), position the cursor over the displayed Zone Number, i.e., "01" using Keys [1] and [2] and change the Zone Number using Keys [3] and [6]. Repeat the zone-description programming procedure for the new zone. Advance to the next zone and repeat until all zones (up to 96) have been programmed.

**ARMING AND DISARMING THE SYSTEM** (For RP3000LCD Keypads only; not applicable to CF3000LCD Keypads.)

**Note:** In the normal disarmed state, only the green STATUS

LED will be on and the display will read "SYSTEM READY". To silence an alarm, enter any User Code, then press the [ON/OFF] Button.

Any of the User Codes or the Service Code (if active) may be used to arm or disarm; an Arm-Only Code may only be used to arm.

**Arming.** To arm, enter the User Code, then press the [ON/OFF] Button. (If a wrong code is entered, the keypad will display "INVALID ENTRY / TRY AGAIN".) The green STATUS LED will go off, the red ARMED LED will go on, and the display will read "EXIT TIME XXX" ("XXX" representing the programmed exit-delay time, in seconds). The exit delay will immediately start counting down toward "000", in 10-second decrements, indicating the available time remaining to exit through an exit/entry door.

**Note:**

1. If *Start Exit Delay After Ringback* is programmed, exit delay will not start until the central station acknowledges receipt by a *ringback* tone at the keypad. The display will read "PLEASE WAIT" while the control panel communicates to the central station. If the ringback tone does not sound within about 30 seconds, the *START EXIT TIME* function (RESET MENU) may be used to manually start exit delay.

2. If *Exit Delay Restart* is enabled, after the panel is armed and the exit door is opened and then closed, exit delay will restart at 60 seconds. If re-entry occurs within this 60-second interval, the alarm device will sound a 2-second warning "chirp", if programmed, as an entry reminder to the user to return to the keypad and disarm.

3. An "s" in the display (e.g. "EXIT TIME XXX s") will appear as a reminder that the system is being armed with the Service Code active. (To turn off the Service Code, disarm, then rearm using a regular Arm/Disarm Code.)

4. If "CHECK TROUBLE" is displayed, check the *DISPLAY SYS TBL* function (DISPLAY MENU) and correct the system trouble. After the trouble is checked, it will be possible to arm within 5 minutes if repairs cannot be made immediately.

**Disarming.** When the exit time has elapsed, the display will read "SYSTEM ARMED". This indicates that upon entering the premises through an exit/entry door, there will be an entry delay to allow time to disarm the panel. The RP3000LCD display will read "ENTRY TIME XXX" ("XXX" representing the programmed entry-delay time, in seconds). The sounder will come on and the entry delay will immediately start counting down toward "000" in intervals of 10 seconds, indicating the available time remaining to disarm the panel. To disarm the panel, enter a valid User Code, then press the [ON/OFF] Button.

**Arming with No Delay.** To cancel the entry delay on the Exit/Entry Zone, press the [INSTANT] Button prior to or after arming. The display will read "SYSTEM ARMED I" and the red LED will flicker. This feature may be used to provide instant protection while on the premises. It will be cancelled automatically upon disarming.

**Priority Arming.** A 2-second tone and "PRIORITY TROUBLE" displayed when attempting to arm indicates a priority condition; that is, a problem exists on at least one zone that has been designated a *Priority Zone*, or a system trouble exists. The trouble(s) must be corrected before the panel can be armed. To check which zone is in trouble, check the *DISPLAY STATUS* function. The display will read "ZONES

FAULTED", then scroll through all the unsecured zones. If a system trouble is indicated, display the system trouble (check DISPLAY MENU).

**Area Arming** (For RP3000LCD Keypads only; not applicable to CF3000LCD Keypads.)

In a partitioned system, any or all secured areas may be armed (or disarmed) simultaneously from either the Overview Mode or the Manager's Mode (if enabled). To arm or disarm any one area, see *Keypad Area Change*, which follows.

**Overview Mode.** The Overview Mode is a high security mode of operation requiring a Level-3 User Code with Overview Option, wherein the status of all areas is displayed at the keypad. (To enable or disable Overview, see *SUPERVISORY MENU: OVERVIEW*). When arming all areas, the "home" area remains disarmed. To arm any one area, see *Keypad Area Change*, which follows.

In the Overview Mode, "OV(-----)" will be displayed, where each dash ("—") represents an area. In programmed areas, the dash will be replaced by one of the following:

- "A" = Area Armed
- "B" = Burglary Zone in Alarm
- "C" = Check Trouble
- "D" = Area in Function-Display Mode
- "F" = Fire Zone in Alarm
- "N" = Normal Fire Area
- "R" = Area Ready
- "T" = Fire Zone in Trouble
- "Z" = Zone Fault

In the Overview Mode, all *ready* areas ("R") *except the "home" area* may be armed simultaneously by pressing [9], [\*], and then entering a Level-3 User Code with Overview option enabled. (**Note:** The User Code must be valid in all areas, otherwise only those areas recognizing the code will arm.) Similarly, all *armed* areas ("A") may be disarmed by entering [0], [\*], and a Level-3 User Code (with Overview). If any zone is not secured, the system will not arm and the keypad will display "CAN'T ARM SYSTEM / AREA # IN TROUBLE", where "#" represents the area number.

**Manager's Mode.** The Manager's Mode, in contrast to the Overview Mode, is a low-security mode of operation. Unlike the Overview Mode, when arming all areas, (press [9], [\*], [enter code]) *the "home" area will also arm*. As in Overview, if any zone is not secured, the system will not arm and the keypad will display "CAN'T ARM SYSTEM / AREA # IN TROUBLE", where "#" represents the area number. To disarm all areas, press [0], [\*], then enter a valid code. To arm any one area, see *Keypad Area Change*.

**Keypad Area Change.** To arm or disarm any one area:

1. Enter the number representing the area to be selected.
2. Press the [\*] Button, then the [ON/OFF] Button. The keypad will display "SYSTEM READY X", where "X" denotes the area selected. **Note:** Fire areas can neither be viewed nor changed.
3. Arm or disarm the area using your code (the code must be valid in that area).
4. To return the keypad to its "home" area, press the [\*] Button, then the [ON/OFF] Button.

**Note:** If the "home" keypad has been changed to another area and unused for more than 5 minutes, it will revert to the home area.

**BYPASSING ZONES** (For RP3000LCD Keypads only; not applicable to CF3000LCD Keypads. Also see *DISABLING FIRE ZONES*, which follows.)

### Security Bypass

Those zones programmed for *Selective Bypass* may be removed from the system prior to arming by users having a code with Authority Level-1 or higher and *Bypass* enabled. Either of the following two methods may be used. **Note:** When the panel is subsequently disarmed, all bypassed zones revert to unbypassed zones (unless Interior-1 Zones are programmed normally bypassed).

#### A. From the "DISPLAY STATUS" Screen,

1. Enter code, then press the [FUNCTION] Button. "DISPLAY STATUS" will appear.
2. Press [ON/OFF] to display status. The number of faulted zones will display briefly, followed by the first faulted zone.
3. Press the [BYPASS] Button to bypass the zone.
4. Press the NEXT ([INTERIOR]) Button to display the next faulted zone and press the [BYPASS] Button to bypass that zone.
5. Repeat Step 4 for each zone to be bypassed. To cancel any bypassed zone, at the zone display, merely press the [BYPASS] Button once again.

After all faulted zones are bypassed, press the [RESET] Button; "SYSTEM READY" will display, indicating that it is now safe to arm.

#### B. From the "DIRECTORY" Screen.

1. Enter code, then press the [FUNCTION] Button until "DIRECTORY" appears.
2. Press [ON/OFF] to display the directory. The number of zones will display briefly, followed by Zone 01.
3. Use the [INTERIOR] (NEXT) and [INSTANT] (PRIOR) Buttons to select the zone to be bypassed.
4. When the zone is displayed, press the [BYPASS] Button. Repeat for each zone to be bypassed. To cancel any bypassed zone, at the zone display, merely press the [BYPASS] Button once again.

### Easy Bypass (Do not enable in UL applications.)

If *Enable Easy Bypass* is programmed, Selective Bypass Zones may be bypassed quickly and easily as follows. (**Note:** This is *not* a high-security feature.)

1. At the "SYSTEM READY" or "ZONE FAULT" display, enter the zone number as a two-digit number (e.g., "01", "15", etc.). Using *Easy Bypass*, zones cannot be bypassed while the panel is armed.
2. Press the [BYPASS] Button.

**Note:** (1) If *Easy Bypass* is not enabled, the foregoing procedure will cause a 4-chirp rejection signal at the keypad, with the display "INVALID ENTRY / TRY AGAIN". (2) When the panel is subsequently disarmed, all bypassed zones revert to unbypassed zones (unless Interior-1 Zones are programmed normally bypassed).

**Interior Zones.** This feature is used to provide perimeter protection while keeping active interior zones disarmed. Two groups of Interior Zones may be programmed for each area. When the [INTERIOR] Button is pressed prior to arming, "11" will display with programmed zone descriptions, indicating Interior-1 zone group; pressing the [INTERIOR] Button again will toggle to "12", Interior-2 zone group. Pressing the [INTERIOR] Button once again will toggle to "11+12", both interior zone groups. All zones designated for the

selected interior group(s) will be bypassed simultaneously when the system is armed.

### DISABLING FIRE ZONES

Fire zones may be disabled (prevented from going into alarm) if the zone is programmed for *Selective Bypass*. Fire zones should not be programmed for *Selective Bypass* if either *Disable Code Entry for Inifo Mode* or *Disable Code Entry for Function Mode Level 1* is programmed. Only users with codes programmed with the *Bypass* option may disable a zone.

**CF3000LCD Keypad.** To disable a Fire Zone using the CF3000LCD keypad, enter code and press [INFO]. Press [NO] until "LIST DIRECTORY?" displays. Press [YES]. Select the desired zone using the [NO] button. Press [DISABLE]. The "DISABLE" reminder should appear (pressing [DISABLE] toggles the zone between *disabled* and *normal*, as displayed by the reminder). Press [RESET]. The "DISABLE" reminder will be on, the "FIRE/TBL" reminder will flash and the keypad will display "NOT NORMAL", indicating that a Fire Zone is disabled. The panel will report a trouble to the central station if it is programmed to report trouble on the zone. To enable a disabled zone, repeat the above procedure.

**RP3000LCD Keypad.** To disable a Fire Zone using the RP3000LCD keypad, enter code and press [FUNCTION]. Press [FUNCTION] until "DIRECTORY" displays. Press [ON/OFF]. Select the desired zone using the [INSTANT] button. Press [BYPASS]. The "BYPASS" reminder should appear (pressing [BYPASS] toggles the zone between *disabled* and *normal*, as displayed by the reminder). Press [RESET]. The "BYPASS" reminder will be on, the "FIRE/TBL" reminder will flash indicating that a Fire Zone is disabled. The panel will report a trouble to the central station if it is programmed to report trouble on the zone. To enable a disabled zone, repeat the above procedure.

### ALARM INDICATION

**Note:** To silence an alarm, enter a valid User Code, then press the [ON/OFF] Button.

Should a burglary alarm occur, the red ARMED LED will flash, and the display will alternately read "ALARM", then the zones violated. Disarm the panel; the display will read "ALARM MEMORY" and will continue to indicate the violated zones until the [RESET] Button is pressed or the panel is armed once again. The alarm conditions will then be stored in the Alarm History Log and the Total Event Log (see *HISTORY LOG*).

### RP3000LCD FUNCTION MODE (For RP3000LCD Keypads only; not applicable to CF3000LCD Keypads.)

The RP3000LCD Keypad provides several utility functions as summarized in the Functional Diagram (see *Appendix*). To enter the Function Mode, enter either a Level-3 User Code or the Dealer Security Code and press the [FUNCTION] Button. While in the Function Mode, scroll through functions using [FUNCTION] and [BYPASS] Buttons; select the function using the [ON/OFF] Button. **Note:** (1) A 4-star menu display (e.g. "\*\*\*\*\*") is a signal to wait 2 seconds for a submenu of related functions (as indicated by  $\Rightarrow$ ) to appear. To bypass the submenu, continue pressing the [FUNCTION] or [BYPASS] Button without waiting. (2) In Commercial Fire systems, those Reset Functions that are accompanied by a pulsing sounder as described herein must be reset by first entering a valid code, then pressing

[RESET].

- **DISPLAY STATUS.** Select to identify all unsecured zones (within the keypad's area) while disarmed. Press the [INTERIOR] Button to scroll through the zones. Manually bypassed zones will be indicated when displaying status.
- **DISPLAY BYPASSED.** Select to display zones that have been deactivated. Press the [INTERIOR] Button to scroll through the zones. (Zones may be bypassed in this mode by entering the zone number, then pressing the [BYPASS] Button.)
- **DIRECTORY.** Displays a list of all programmed zone descriptions in the keypad area. Press the [INTERIOR] Button to scroll through the zones. (Zones may be bypassed in this mode by pressing the [BYPASS] Button at the zone display.) To return to the system, press the [RESET] Button at any time.
- **BELL TEST.** This test will activate the burg relay output (while disarmed) for about 2 seconds. If the device does not sound, it may be defective.
- **TELEPHONE LIST.** The panel can function as an autodialer to any of four programmed telephone numbers. (Telephone numbers must be programmed through Napco PCD3000 Quickloader software.) Select Telephone #1-4 using [INTERIOR] and [INSTANT] Buttons, then press the [ON/OFF] Button. Pick up the phone to initiate dialing of the displayed number. (The phone will appear to be disconnected while dialing but will start to ring after a few seconds.)
- **DISPLAY MENU.** At the "\*\*DISPLAY MENU\*\*", wait about 2 seconds for the submenu to display, as follows. (To suppress the following submenu, press the [FUNCTION] Button within the 2-second delay period.)
  - ⊗ **DISPLAY SYS TBL.** Select to "check trouble" (LOW BATTERY, AC POWER LOSS, etc.). Wait for the display to scroll through multiple system troubles, or use the [INTERIOR] and [INSTANT] Buttons to manually scroll.
  - ⊗ **DISPLAY FIRE ALM.** When a fire alarm is detected, the keypad will alternately display "\*\*\*\*\*FIRE\*\*\*\*\*" and the zone number(s) along with a pulsing sounder and a steady "FIRE/TBL" display. Correct the condition and press the [RESET] Button to clear the display and return the "SYSTEM READY" message. If the fire condition cannot be corrected immediately, press the [RESET] Button to silence the sounder and return the "SYSTEM READY" display, however the steady "FIRE/TBL" reminder will continue to display. (It is possible to arm in this condition.) To recall the Fire Zone(s) in alarm, access *DISPLAY FIRE ALM* at the DISPLAY MENU and scroll through the zones using the [INTERIOR] Button. Correct the problem, then press the [RESET] Button to restore the "SYSTEM READY" condition.
  - ⊗ **DISPLAY FIRE TBL.** When a fire trouble is detected, the keypad will alternately display "FIRE TROUBLE" and the zone number(s) along with a pulsing sounder and a flashing "FIRE/TBL" display. Correct the trouble and press the [RESET] Button to clear the "FIRE TROUBLE" display and return the "SYSTEM READY" message. If the trouble cannot be repaired immediately, press the [RESET] Button to silence the sounder and return the "SYSTEM READY" display, however the flashing

"FIRE/TBL" reminder will continue to display. (It is possible to arm in this condition.) To recall the zone(s) in trouble, access *DISPLAY FIRE TBL* at the DISPLAY MENU and scroll through the zones using the [INTERIOR] Button. Correct the problem, then press the [RESET] Button to restore the "SYSTEM READY" condition.

- ⊗ **DISP OP/CL SCHED.** Napco's PCD3000 Quickloader software offers a complex array of programmable opening and closing suppression windows, by area, for all days of the week, for both normal and holiday schedules. A two-line display of the programmed schedule may be read at the keypad. The first line indicates:
  - the day of the week
  - opening or closing suppression window
  - "AUTO", if autoarming
  - normal (or delayed) schedule (see below)

To scroll through the days of the week, use the [INTERIOR] and [INSTANT] Buttons. To display the second line, hold down the [\*] Key. (Note: The second line will display momentarily whenever a new schedule is selected.) The second line indicates the starting and ending times of the suppression window.

The closing of any suppression window may be delayed up to four hours at the keypad, or the window may be totally disabled, up to one week in advance. Select the *DAY/OP/CL* schedule using the [INTERIOR] and [INSTANT] Buttons. Then select the delay (1-4 hours) or disable using the [ON/OFF] Button. Note: If the schedule includes autoarming, arming will be delayed accordingly. (Autoarming can be disabled or delayed by area using PCD3000 software.)

- **SUPERVISORY MENU.** At the "\*\*SUPERVISORY\*\*" display, wait about 2 seconds for the submenu to display, as follows. (To suppress the following submenu, press the [FUNCTION] Button within the 2-second delay period.)
  - ⊗ **OVERVIEW.** This mode provides a system status display of all partitioned areas at a glance. (Note: It is likely that the keypad selected for the Overview Mode will remain in that mode. To convert the keypad back to its original use as an area keypad, enter the Function Mode and, at the \*\*SUPERVISORY\*\* menu, access *OVERVIEW* once again. The display will revert to "SYSTEM READY".) Also see *Overview Mode*.
  - ⊗ **ACTIVATE CHIME.** This option will sound a tone at the keypad when a zone programmed as *Chime Zone* is violated. The duration of the tone is programmable. A "c" will appear in the display as long as the Chime Mode is active. To turn off the Chime Mode, select *ACTIVATE CHIME* again.
  - ⊗ **ACTIVATE WATCH.** This option, if programmed, permits all zones designated as *Day Zones* to be turned on. When accessed, a "w" will appear in the display as long as the Watch Mode is active. To deactivate the Watch Mode, arm, then disarm.
  - ⊗ **GUARD TOUR (ON/OFF).** A Guard-Tour Schedule is programmable through Napco's PCD3000 Quickloader Software. *GUARD TOUR* is toggled on and off by pressing the [ON/OFF] Button. When *GUARD TOUR* is toggled on, the programmed starting time of the tour will be signalled by all guard-tour keypads puls-



ing and displaying "DO GUARD TOUR / ENTER CODE". The tour must be started within 10 minutes of the signal. Entering the Guard-Tour Code at each keypad will silence its sounder and restore its "SYSTEM READY" display. Silencing the last keypad ends the tour. If the tour is not completed within the programmed duration, the panel may be programmed to report to the central station, trip the burg relay (or one of the 64 external relays), or both (or neither).

- **RESET MENU.** At the "\*\*RESET MENU\*\*" display, wait about 2 seconds for the submenu to display, as follows. (To suppress the following submenu, press the [FUNCTION] Button within the 2-second delay period.)

- ⊗ **RESET DEVICES.** (For Commercial Fire Systems using CF5530) Access for initiating devices (e.g. 2-wire or 4-wire smokes) powered from the Reset Relay, which require a momentary power interruption for reset.
- ⊗ **FIRE SILENCE.** (For Commercial Fire Systems using CF5530) Access to silence a fire sounding device.
- ⊗ **RESET FIRE AUX 1.** (For Commercial Fire Systems using CF5530) Access to reset the CF5530 Aux. 1 Relay.
- ⊗ **RESET FIRE AUX 2.** (For Commercial Fire Systems using CF5530) Access to reset the CF5530 Aux. 2 Relay.
- ⊗ **RESET SYSTEM TBL.** System troubles normally latch and display and sound at the keypad. Pressing the [RESET] Button will silence the sounder and cause "CHECK TROUBLE" to be displayed. Correcting the trouble will clear most system trouble indications, however the following system troubles require a Level-2 or -3 code for manual reset (enter code; access *RESET SYS TBL* from RESET menu; then press [ON/OFF].)
  - EZM Tamper
  - Keypad Tamper
  - Sensor Watch
  - Service Reminder
  - User Memory Fail\*
  - Dealer Memory Fail\*

\*Internal system memory error.

- ⊗ **RESET SENSOR MSG.** Resets a PIR Supervision system trouble.
- ⊗ **START EXIT TIME.** If the central station ringback signal has not been received within about 30 seconds, a communication problem may exist. Select *START EXIT TIME* to start exit delay manually.
- **DIAGNOSTIC MENU.** At the "\*\*DIAGNOSTIC\*\*" menu, wait about 2 seconds for the submenu to display, as follows. (To suppress the following submenu, press the [FUNCTION] Button within the 2-second delay period.)
  - ⊗ **FAULT FIND.** This troubleshooting aid will help the installer locate swingers. When accessed, two things occur: (a) the loop response of each zone is set for the fastest response time, and (b) causing or repairing a fault activates the sounder for about 3 seconds. Tapping and poking at suspect points, the installer can easily locate swingers by listening for the beep. This eliminates the need of returning to the keypad to visually check after each attempt. Press the [RESET] Button to restore normal operation. (Arming the sys-

tem automatically cancels the Fault-Find Mode.)

- ⊗ **ACTIVATE LOCATE.** This feature will help the user find zone troubles and indicate when they are repaired. When accessed, the sounder will come on and the display will read "LOCATE", then scroll through the zones in trouble. As each zone is corrected, the sounder will stop momentarily, signalling its repair, and the display will indicate the remaining zones in trouble. The sounder and display will continue in this manner until all zones are repaired, or until the [RESET] Button is pressed.
- ⊗ **EZM ZONE FIND.** To find the physical location of an EZM, enter the number of any zone on that EZM, then press the [ON/OFF] Button. This will cause the EZM sounder to pulse continuously until silenced. To silence the sounder, press the [RESET] Button on any keypad.
- ⊗ **COMM TEST TO CS.** Press the [ON/OFF] Button to send a digital dialer test code to the central station using the system account number. A successful test will clear a *Failure to Communicate* system trouble.
- **HISTORY LOG.** The History Log documents the 800 most recent events. At the "\*\*HISTORY LOG\*\*" menu, wait about 2 seconds for the submenu to display, as follows. (To suppress the following submenu, press the [FUNCTION] Button within the 2-second delay period.)
 

**Note:** Event-log displays comprise two lines. To display the second line, hold down the [\*] Key.

  - ⊗ **ALARM EVENT LOG.** Displays most recent alarm events. Line 1 displays event and date. Line 2 displays time, area and zone. To check prior alarm events, scroll back using the [INSTANT] Button. If a printer is connected, the Alarm Event Log may be printed by pressing [8], then [ON/OFF]. The entire log will be printed unless printing is terminated by pressing [RESET].
  - ⊗ **TOTAL EVENT LOG.** Displays most recent events of all types. Line 1 displays event and date. Line 2 displays time and, if applicable, area and zone or user. To check prior events, scroll back using the [INSTANT] Button. If a printer is connected, the Total Event Log may be printed by pressing [8], then [ON/OFF]. The entire log will be printed unless printing is terminated by pressing [RESET].
  - ⊗ **FIRE EVENT LOG.** Displays most recent fire events. Line 1 displays event and date. Line 2 displays time, area and zone. To check prior fire events, scroll back using the [INSTANT] Button. If a printer is connected, the Fire Event Log may be printed by pressing [8], then [ON/OFF]. The entire log will be printed unless printing is terminated by pressing [RESET].
  - ⊗ **OP/CL EVENT LOG.** Displays most recent openings and closings. Line 1 displays event and date. Line 2 displays time, area and user. To check prior events, scroll back using the [INSTANT] Button. If a printer is connected, the Opening/Closing Event Log may be printed by pressing [8], then [ON/OFF]. The entire log will be printed unless printing is terminated by pressing [RESET].
  - ⊗ **SYSTEM EVENT LOG.** Displays most recent system events. Line 1 displays event and date. Line 2 displays time and other pertinent information, where neces-

sary, depending upon event. To check prior system events, scroll back using the [INSTANT] Button. If a printer is connected, the System Event Log may be printed by pressing [8], then [ON/OFF]. The entire log will be printed unless printing is terminated by pressing [RESET].

- **AUTOARM FUNC.** Use this function to (a) delay programmed autoarming up to 4 hours, 15 minutes or (b) initiate autoarming in 4 hours, 15 minutes as follows. **Note:** Autoarming may not be used in III installations.

At the "AUTOARM IN 1-4HR" display:

- For 1hr, 15min delay: press [1], then [ON/OFF].
- For 2hr, 15min delay: press [2], then [ON/OFF].
- For 3hr, 15min delay: press [3], then [ON/OFF].
- For 4hr, 15min delay: press [4], then [ON/OFF].

Fifteen minutes prior to arming, the siren will sound a 2-second warning and the keypad will begin a 15-minute countdown with the sounder pulsing. Within this countdown window, arming may be delayed an additional 1 to 4 hours, as above, or autoarming may be cancelled by arming and disarming the panel.

- ✕ **AUTO ARM SCHED.** Displays the autoarm schedule programmed by the PCD3000 software. Press the [ON/OFF] Button to execute, then use [INTERIOR] and [INSTANT] Buttons to scroll forward and back through the week. While the programmed schedule cannot be changed at the keypad, autoarming may be delayed up to four hours at the keypad, or it may be totally disabled, up to one week in advance. Select the day using the [INTERIOR] and [INSTANT] Buttons. Then select the delay (1-4 hours) or disable using the [ON/OFF] Button.

Fifteen minutes prior to autoarming, the siren will sound a 2-second warning and the keypad will begin a 15-minute countdown with the sounder pulsing. Within this countdown window, arming may be delayed an additional 1 to 4 hours (using *AUTOARM IN 1-4HR* function), or autoarming may be cancelled by arming and disarming the panel.

- **ACTIVATE PROGRAM.** At Keypad No. 1, press the [ON/OFF] Button to activate the User Program (Program-1) Mode or Dealer Program (Program-2) Mode, depending upon the code entered. Scroll through the programmable functions using [INTERIOR] and [INSTANT] Buttons. Refer to *USER KEYPAD PROGRAMMING* in Section 3, *KEYPAD PROGRAMMING* in Section 4, and the *Appendix* for operation of the keypad in the Program Modes. **Note:** Keypad No. 1 may be located in any area.
- **DOWNLOAD.** Used on-site at Keypad No. 1 to download a control-panel program from the PCD3000. To initiate the data transfer, access the *DOWNLOAD* function, then press the [ON/OFF] Button to execute. **Note:** Keypad No. 1 may be located in any area.

**CF3000LCD MENU MODE** (For CF3000LCD Keypads only; not applicable to RP3000LCD Keypads.)

The CF3000LCD Keypad provides a menu-driven assortment of utility functions in the Menu Mode. The complete Info menu is provided below in its displayed sequence.

1. To enter the Menu Mode, enter a valid code (if necessary), then press [INFO].
2. Press [YES] or [NO]. [YES] will execute the displayed

function and terminate the Menu Mode; [NO] will step to the next available function.

3. To return to normal keypad operation, press [RESET]. The keypad will automatically return to its normal operating mode if no activity is detected within 1 minute.

4. Hold down the [\*] key to display the second line.

- **SILENCE ALARMS? (YES/NO).** Causes the fire bells (or other fire signalling devices) to silence. "FBS" (fire bell silenced) will display until the Fire Zone has been reset. An alarm on another zone will sound the fire bell again.
- **RESET ZONES? (YES/NO).** Resets Fire Zones after the device causing the alarm has been restored. Also, momentarily removes power to devices that require a power interruption for resetting. *Important:* If more than one smoke detector is on a zone, be sure to note which one caused the alarm before resetting the device.
- **RESET AUX FIRE1? (YES/NO).** Pressing [YES] resets a device wired to the Aux 1 relay.
- **RESET AUX FIRE2? (YES/NO).** Same as above, but for Aux 2 relay.
- **DISP FIRE ALARM? (YES/NO).** Displays zones that have been activated and not reset. Pressing [YES] will step forward to the next higher zone; pressing [NO] will step back to the next lower zone.
- **DISP FIRE TRBL? (YES/NO).** Displays zones that have a wiring fault (trouble).
- **DISPLAY DISABLED ZONES? (YES/NO).** Indicates zones that have been disabled. (Zones are disabled and enabled using the *LIST DIRECTORY* Function, which follows.)
- **DISP SYS TRBL? (YES/NO).** If "NOT NORMAL" is displayed with a "SYS TBL" reminder, this function is used to display system troubles (Low Battery, AC Failure, etc.).
- **SILENCE SYS TRBL? (YES/NO).** Silences the system-trouble keypad sounder alert, however does not reset the system trouble condition.
- **FIRE DRILL? (YES/NO).** Turns on the fire bells to simulate a fire alarm condition. Does not cause a central-station transmission. To terminate the Fire Drill, enter code (if necessary) and press [SILENCE]. (The fire bells may silence automatically after a predetermined time if so programmed.)
- **LIST DIRECTORY? (YES/NO).** Displays the names of the Fire Zones for reference and for disabling devices. To enable or disable a device, enter code (if necessary) and press [DISABLE] while the appropriate zone is displayed.
- **DISP FIRE LOG? (YES/NO).** Displays any fire events that are contained in the 800-event log. Pressing [NO] will step back to earlier log entries; pressing [YES] will step forward to more recent log entries. Pressing [8], then [SILENCE] will cause all fire events to print, if a printer is installed.
- **DISP SYSTEM LOG? (YES/NO).** Displays such system events as system troubles (AC Failure, Low Battery, etc.), bell silence, fire drill, restores, etc. Pressing [8], then [SILENCE] will cause all system events to print, if a printer is installed.
- **SEND TEST REPORT? (YES/NO).** Sends a test signal to the central station. If the test fails, a *Failure-to-Communicate* message will display.
- **TEST ALARMS? (YES/NO).** Sounds the bells for 3

seconds.

- **DISP PHONE LIST? (YES/NO).** Displays the telephone numbers that have been programmed (Service number, Central-Station number, etc.).
- **PROGRAM MODE? (YES/NO).** The Program Mode is used to customize User Codes, Exit/Entry Times and Zone Descriptions, etc. Access to the Program Mode requires a Level-3 User Code with *Program* Option enabled. The User Program Mode is accessed from the Menu Mode as follows:
  1. Enter a Level-3 User Code (with *Program* Option), then press the [INFO] Button ("SILENCE ALARMS?" will appear).
  2. Press the [DISABLE] Button repeatedly until "PROGRAM MODE?" is displayed, then press the [SILENCE] Button.
- **ENABLE DOWNLOAD? (YES/NO).** Used on-site at Keypad No. 1 to download a control-panel program from the PCD3000. Press [YES] to access the *DOWNLOAD* Function; press [SILENCE] to initiate the data transfer.

#### PRINTER PORT J1

A parallel printer port, J1, is provided for hardcopy printouts of events as they occur. A printer adaptor cable, Napco Part No. PCBL, is required to interface your printer cable to J1. While Napco's PCD3000 Quickloader Software offers a convenient means of selecting event-log printouts, the event logs can also be printed from the keypad. **Note:** In the event of a power failure, the panel will not send information to the printer.

#### Block Printing.

To print the entire event log, access any event log. When the most recent event displays, press Key [8], then [ON/OFF]. The printer will print the entire event log unless interrupted. To terminate the printout, press the [RESET] Button.

#### RP3000LCD KEYPAD MESSAGES

The RP3000LCD Keypad can display the following messages. (Programming displays are described in *USER KEYPAD PROGRAMMING* earlier in this section, and *DEALER KEYPAD PROGRAMMING* in Section 4.)

**SYSTEM READY CW** - All zones operating; system can be armed. C = Chime Mode on; W = Watch Mode on.

**PLEASE WAIT** - Panel reporting to central station on arming. Wait for ringback signal to exit.

**EXIT TIME XXX SI** - Exit delay in progress. xxx = exit time remaining in 10 second decrements; s = Service Code active; i = arming with Instant protection.

**ENTRY TIME XXX** - Entry delay in progress. xxx = entry time remaining in 10-second decrements.

**SYSTEM ARMED SI** - Panel armed. s and i indications as above.

**CHECK STATUS CW** - One or more zones not secured. Display status for zone description(s). C and W indications as above.

**PRIORITY TRBL** - Arming attempted with Priority Zone in trouble. Display Status. Correct trouble to arm.

**DAY ZONE TRBL** - Trouble condition on Day Zone, followed by one or more zone descriptions.

**CHECK TROUBLE** - System trouble. After trouble is checked, panel may be armed within 5 minutes.

**INVALID ENTRY/TRY AGAIN** - Wrong code/time/area number entered.

**CAN'T ARM SYSTEM** - In *Overview* or *Manager's Mode*, one or more areas not secured.

**ALARM** - Alarm condition, followed by one or more zone descriptions.

**\*\*\*\*\*FIRE\*\*\*\*** - Fire alarm condition, followed by one or more zone descriptions.

**FIRE TROUBLE** - (When *Fire Status* displayed) trouble condition on a Fire Zone. Press the [RESET] button to silence the sounder. Correct the trouble, then press the [RESET] button again.

**FIRE ALARM** - (When *Fire Status* displayed) alarm condition on a Fire Zone. Press the [RESET] button to silence the sounder. Correct the cause of the alarm, then press [RESET] again.

**NORMAL** - (When *Fire Status* displayed) Fire Zones normal.

**ZONES BYPASSED** - (When *Zones Bypassed* displayed) indicates zones that have been deactivated.

**OV(R---)** - Overview Mode (Status of up to 8 areas):  
R = Zone Ready; also, Z = Zone Fault; A = Armed;  
B = Burglary Output; F = Fire Output; T = Fire Trouble;  
C = Check Trouble; D = Display Mode; N = Fire Area Normal.

**SYSTEM TROUBLE** - (When *System Troubles* displayed) indicates system trouble(s) (below).

**AC POWER LOSS** - Power failure. Check power transformer. Check for blown fuse or circuit breaker; general power outage.

**ACTIVITY FAILURE** - No trip detected on PIR Supervision Zone within programmed Sensor-Watch time. To reset, press [FUNCTION] Button, then Key [9].

**BUS 1 FAIL** - Failure of 4-Wire Bus 1. Check Terminals 19/20.

**BUS 2 FAIL** - Failure of 4-Wire Bus 2. Check CF5530. A report will be transmitted to the central station on either of above bus failures.

**FAIL TO COMM** - Unsuccessful communication to central station.

**TELCO 1 FAIL** - System trouble displays after a programmed delay.

**TELCO 2 FAIL** - (CF5530 Board.) System trouble displays after a programmed delay.

**EZM FAILURE XX** - Failure of an expansion zone module. xx = module number.

**LOW BATTERY** - If battery is not recharged within 24 hours, replace it.

**TAMPER EZM XX** - EZM module cover removed. xx = module number.

**TAMPER KEYPAD XX** - Keypad cover removed. xx = keypad number.

**KEYPAD FAILURE X** - Keypad defective. x = keypad number.

**XX OUT OF SYSTEM** - Keypad inoperative (xx = keypad number; call for service).

**ERROR USER MEM** - Internal memory error. At RESET MENU, select *RESET SYSTEM TBL*. Press the [ON/OFF] button then the [RESET] button.

**ERROR DLR MEM** - Same as above.

**ALARM MEMORY** - (After panel disarmed) displays zones violated.

**FAULT FIND** - Fault-Find Mode activated.

**LOCATE** - Locate Mode activated.

**Service Message.** A service message can be programmed through the PCD3000 Quickloader software

(event-schedule screen) to remind the user to arrange for scheduled maintenance. At the programmed date and time, the keypad sounder will start to pulse and the display will read "SERVICE REMINDER". This condition will behave as

a system trouble and may be cleared as such, i.e., press [RESET] to silence sounder; access *RESET SYSTEM TBL* from RESET menu, then press [ON/OFF].

## NOTES

## 4. PROGRAMMING

The control panel is programmed by either of the following methods, each of which is described in detail in the following paragraphs.

- Local or remote downloading using an IBM PC-compatible computer with Napco PCD3000 Quickloader software and interface;
- Keypad programming.

**Note:** Commercial-Fire systems must be programmed using PCD3000 software, either locally or remotely.

### DOWNLOADING FROM A COMPUTER

#### Local Downloading

For convenience, a local panel (panel only) may be powered from the PCI2000 via the 6-conductor cable connected at J3. (Refer to the wiring instructions accompanying the PCI2000/3000.) **Note:** This procedure should be used prior to installation, before peripheral devices are connected.

#### Remote Downloading

Data may be remotely downloaded to the panel via telephone lines using an IBM PC-compatible computer with Napco PCD3000 software and PCI2000 interface. On-screen prompting and the extensive use of help menus simplify programming, and an error-checking mode locates omissions and incompatible data to reduce the possibility of mistakes. Remote downloading requires (a) a modem compatible with the PCI2000 and (b) PCD3000 Software. **Note:** In Commercial Fire installations, all programming or reprogramming is automatically reported to the central station. A complete functional checkout is required after any programming or reprogramming.

**Callback Method.** This method is used to download to an unattended panel. The panel will accommodate an answering machine at the site only if line seizure is used on the house phones unless *Answering Machine Pickup Without Line Seizure* is programmed. **Note:** (1) The number of rings programmed into the panel must exceed that of the answering machine. (2) *Callback-Method Download* and *Answering Machine Pickup Without Line Seizure* are automatically disabled in local Commercial-Fire installations.

**Function Mode.** (**Note:** Downloading must be initiated from Keypad No. 1.) Call the central station from the site for a *manual* download. During this procedure, voice contact will be lost, therefore both the installer and the computer operator should be familiar with the operation. When a steady high-pitched tone is heard at the site phone, access the *DOWNLOAD* Function then press the [ON/OFF] Button; the site phone will go dead. Hang up the phone and wait for a call from the central station confirming a successful download. **Note:** This is the only method of remote downloading available for local Commercial-Fire installations.

### KEYPAD PROGRAMMING

**Note:** (1) Only the main keypad (designated Keypad #1) may be used for programming (see *Keypad Assignment*, Section 3), however this keypad may be located in any area. (2) In Commercial-Fire installations, the program may be viewed, but not altered.

Keypad Programming may be divided into two sub-groups: User (Program-1) Mode and Dealer (Program-2)

Mode. *USER KEYPAD PROGRAMMING* (covered in Section 3) is limited to user codes, exit/entry times and zone descriptions. In the Dealer Program Mode, the keypad is capable of programming several additional functions.

#### Dealer Keypad Programming

Set the keypad to the Dealer Program Mode: Enter your Dealer Program Code, then press the [FUNCTION] Button repeatedly until "ACTIVATE PROGRAM" is displayed. (If you pass it, scroll back using the [BYPASS] Button.) At "ACTIVATE PROGRAM", press the [ON/OFF] Button to enter the Dealer Program Mode. The display will briefly read "PROGRAM2 #XXX" (indicating Dealer Program Mode, where "XXX" denotes the software versions for both control panel and keypad) followed by "EXIT TIME" and several other user-programmable options previously covered. The following dealer-only options are also programmable:

- **Program Code.** The Program Code allows access to the Dealer Program (Program-2) Mode. Program up to six digits. A minimum of four is recommended.
- **Date.** Enter the date using the format MM/DD/YY where *M* = month; *D* = date; *Y* = year. Position cursor using Keys [1] and [2]; change date using Keys [3] and [6], then press the [ON/OFF] Button. Date and time are displayed together at the "SYSTEM READY" screen by holding down the [\*] Key.
- **Time.** Enter the time using the format HH:MM/AP where *H* = hours; *M* = minutes; *A/P* = am/pm. Position the cursor using Keys [1] and [2]. Change the time using Keys [3] and [6] (either of which will also toggle *am/pm*). Date and time are displayed together at the "SYSTEM READY" screen by holding down the [\*] Key.

#### Address Program Mode.

To enter the Address Program Mode at any time from the Dealer Program Mode, press [RESET]. (To exit the Address Program Mode at any time, press [RESET] again.) In the Address Program Mode, the display will indicate "ADDR=0000 DATA = ●●". (Dots in the data display represent blanks.) Upper-case functions shown in parentheses indicate the buttons' secondary functions.

**Note:** The Dealer Program Mode may be accessed while the panel is armed if the Dealer Security Code is entered within 5 minutes of (a) power-up or (b) control-panel reset, unless the panel is first disarmed and then rearmed or the [RESET] Button is pressed.

In this mode of operation, the keys no longer perform as expected: Keys [1] and [2] position the cursor left and right respectively within the display; Keys [3] and [6] scroll up and down respectively through ADDR numbers 0-9; and DATA numbers 1-9, 0, letters B, C, D, E, F, and ● (which represents a *blank*) at the selected cursor position. The following buttons also take on new meanings in the Program-2 Mode:

- [INTERIOR] (NEXT) scrolls the display line forward to the next address and reads the data in that address (hold down NEXT for fast forward).
- [INSTANT] (PRIOR) scrolls the display line backward to the previous address and reads the data in that address (hold down PRIOR for fast reverse).
- [0] (CLEAR) clears the data at the selected address.
- [\*] (READ) reads the data in the address manually

selected (when the address is manually entered, the data in that address are not read until the READ Button is pressed).

- [ON/OFF] (SAVE) stores the programmed data in memory. Press [RESET] to exit the Address Program Mode.

**Keypad Programming Workbook.** The Keypad Programming Workbook (WI641) is completed when planning system features and communicator information for the particular installation. **Note:** Most of the addresses shown comprise two data "nibbles", left and right. Program the *left nibble* on the *left* data-display segment, and the *right nibble* on the *right* segment. For those addresses having only *one* programmable nibble, program the *right* segment only; the left segment should display a ● (blank).

Refer to the glossary for programming information and instructions. Save the Keypad Programming Workbook for future reference.

### GENERAL PROGRAMMING STEPS

1. Contact the central station to confirm receiver format, data format, event codes, subscriber numbers and telephone number(s).
2. Complete the Keypad Programming Workbook. Select

the desired features by circling the respective "address" boxes. Refer to the GLOSSARY for guidance in selecting "data" entries (1,2,4,8).

3. Program the data entries in the boxes in the Keypad Programming Workbook into the respective addresses. The display will show the entry numerically, but will display "0" for the number 10, and letters "B", "C", "D", "E", and "F" for the numbers 11 through 15, respectively. To program a 10, enter "0". To program 11 through 15, enter "B" through "F" respectively.

ENTRY TOTAL	DISPLAY
10	0
11	B
12	C
13	D
14	E
15	F

The default program is in memory when shipped from the factory and is loaded on initial power-up. (See *Default Program* in Glossary.)

### NOTES

## 5. GLOSSARY & PROGRAMMING INFORMATION

**Note:** Refer to the Keypad Programming Workbook WI641 for address numbers.

### Abort Delay

A delay period that allows cancellation of the central-station report. This is done by disarming the control panel within the delay period. Program zones for *Abort Delay*; see *Time Selection* for delay time.

**Note:** If *Abort Delay* is selected for a 24-Hour Zone, the zone must be cleared before disarming the panel.

### Ac Failure

#### Ac-Fail Report Delay

#### Enable Brownout Limits on Ac Failure

If ac power is removed from the control panel, "AC POWER LOSS" will display at the keypad with a flashing "SYS TBL" reminder and a pulsing sounder. Press the [RESET] Button (after entering code, in Commercial Fire systems) to silence the sounder; the "SYS TBL" reminder will come on and "CHECK TROUBLE" will appear in the display. To arm, first check the system trouble; the display will read "SYSTEM READY", but the "SYS TBL" reminder will remain on. If a User Code is entered within 5 minutes, the panel may be armed successfully.

*Ac Failure* may be programmed to activate any alarm output and/or report to a central station (program *Panel AC-Fail Report Code*). An alarm and/or restore report to the central station will occur immediately unless an *Ac-Fail Report Delay* is programmed. See *Time Selection*.

In Commercial Fire installations, if not using the PS3000 Power Supply, program *Enable Brownout Limits on Ac Failure*. This will reduce the ac-failure detection and restore limits in order to comply with UL specifications. When an ac failure is detected, the Auxiliary Relay will trip and will remain activated until ac is restored. **Note:** A BDH Harness must be installed unless the PS3000 Power Supply is used.

### Access Control (Panel Access) on Auxiliary Relay

#### Auxiliary Relay Access Control Time

#### Remote Access

#### Access Only

#### Access Logging

**Note:** The MA3000 has not been evaluated by UL for compliance with UL294 (Access Control Systems).

If selected, entering the Access Code while disarmed will trip the Auxiliary relay. This is commonly used to activate a door strike for the purposes of remotely unlocking a door. Each keypad is individually selected for *Access Control* (see *Keypad Features*). Also program *Auxiliary Relay Access Control time* (see *Time Selection*). **Note:** Do not program the Auxiliary Relay as an output on alarm.

*Remote Access* is selectable for any keypad 1 through 8 by appropriate programming of the Access Byte part of any User Code. Program the Access Byte for those keypad numbers (1 through 8) that are to respond to the User Code (see *Remote Access Code* and page 4 of the Programming Workbook, WI641). Note, however, that if the Access Byte is programmed, the code will no longer function as an Arm/Disarm Code. Also, if *Access Only* is programmed for any keypad, that keypad will be dedicated for remote access. It will normally display "ENTER CODE" and will no longer be capable of arming or disarming.

Entering a valid code at the keypad will cause a 5-second

output on the keypad's PGM line with a pulsing sounder and the display "ENTER NOW". If *Access Logging* is programmed, remote access control will be added to the event log by keypad.

### Access Number for Outside Line

Some subscribers will have a telephone system that requires one digit to access an outside line before the telephone number can be dialed. Also, the first dial tone encountered (prior to the access number) may have a frequency that is different from that of the accessed dial tone (440Hz). One or more 4-second Pre-Dial Delay "D"s may be entered before the access number instead of a dial tone with frequency "E". See *Pre-Dial Delay; Telephone Numbers*.

If the subscriber's system uses an access number, contact the telephone-equipment supplier to find out if a dial tone other than 440Hz is received prior to dialing the access number. If the communicator must delay before dialing the access number instead of attempting to recognize the dial tone, find out how many 4-second delays must be programmed.

### Alarm on Day Zone See Day Zone

### Alarm Outputs (See Wiring Diagram for UL requirements.)

The MA3000 has four Form-C relay outputs: (a) Burglary; (b) Fire; (c) Auxiliary; and (d) Reset. Each has a related jumper (B, F, A, and C, respectively) that may be cut for dry contacts.

The following table summarizes wiring for signalling an alarm in typical installations. See *Time Selection* for timeout durations.

OUTPUT	WIRING	REMARKS
Burglary Pulsing Fire	Bell on 5(+) & 16(-)	Single bell; program Burg Relay for Burg; Pulsed Burg for Fire
Fire Bell; Burglary Bell	8(+) & 16(-); 5(+) & 16(-)	Separate fire & burg bells. Program Burg Relay for Burg; Fire Relay for Fire
Aux. Relay	9(C); 10(NC); 11(NO)	
Reset Relay	E22(C); 12(NC); 13(NO)	
Reset Relay as Smoke Reset	13(NC)(+); 16(-)	To smoke power. Program ENABLE FIRE RESET (by area)

### Alarm Outputs

In UL installations, see *Time Selection* for timeout requirements.

**Note:** All relays are "wet" contacts. For dry contacts, cut respective jumper (see *Wiring Diagram*).

### Required Programming for Commercial Fire Installations

To ensure that the audible alarm for fire is distinguishable from that of burglary, alarm outputs must be programmed as follows.

### Pulsing Supervised Fire Relay not programmed:

	ALL FIRE ZONES	ALL AUDIBLE BURG ZONES
BURGLARY RELAY	NO	NO
PULSED BURGLARY RELAY	NO	YES
SUPERVISED FIRE RELAY	YES	NO

### Pulsing Supervised Fire Relay programmed:

	ALL FIRE ZONES	ALL AUDIBLE BURG ZONES
BURGLARY RELAY	NO	YES
PULSED BURGLARY RELAY	NO	NO
SUPERVISED FIRE RELAY	YES	NO

**Alarm/Alarm Restore Telco 1/Telco 3** See Report Telco 1/Telco 3

**Alarm/Alarm Restore Telco 2** See Backup Report on Telco 2

### Alarm Verification

If programmed, an alarm on any Fire Zone will cause all zones to power down for 12 seconds. (All devices must be wired with + power on Terminal 13.) After this time, power is restored and a 4-second power-up time is started. Thereafter, the zone will be active again. This represents a total processing delay of 16 seconds from the time the alarm is first detected. If an alarm condition still exists at this time or reoccurs within 2 minutes, an alarm will be initiated, otherwise the zone will return to its original state. **Note:** A zone programmed for *Alarm Verification* must be programmed as a *Fire Zone* as well.

### Ambush

A one or two-digit code that is entered immediately prior to (and as part of) the regular Arm/Disarm Code. This will access the Ambush Zone, typically causing a silent report to be sent to a central station. Thus, should a user be forced to disarm by an assailant, he can silently signal an emergency while appearing to be merely disarming the system. The Ambush Zone will automatically report when programmed to report on alarm.

To program the ambush feature, (a) program Ambush to report on alarm; (b) enter 1 or 2 digits as the Ambush Code; and (c) enter an Ambush-Zone Alarm Report Code. Each keypad is enabled for Ambush individually (see *Keypad Features*).

Inform the user what the Ambush Code is, and that his Arm/Disarm Code must be entered less than 10 seconds after the Ambush Code for an ambush report to be sent.

**Answering Machine Pickup Without Line Seizure** See *Callback-Method Download*

### Anti-Jam Time

If the communicator does not detect a dial tone within 12 seconds, the *Anti-Jam* feature will be activated. That is, the communicator will go off line for a 16-second anti-jam interval in order to free the telephone circuit from an incoming call, then make another 12-second attempt at dial-tone detection. If still unsuccessful, the communicator will again go off line for 16 seconds, then proceed to dial anyway.

### Areas

#### Zone Area 1–Zone Area 8

Although the default program will automatically set up Zones 1 through 8 for *Zone Area 1*, the panel may be partitioned into up to eight areas. Each zone must be assigned to at least one area. Gaps in areas are not permitted. If a zone is selected for more than one area, that common zone will not arm until all areas are armed. If any zone disarms, the common zone will disarm.

In a multiple-area system, be sure to also program

- *Enable User Code by Area* (see *User Codes/Authority Levels*);
- *Keypad Area Assignments*
- *Bell Control* (determines which bells an area may silence);
- *Subscriber Opening/Closing ID Numbers* and *Event ID Numbers* (if reporting);
- *System Trouble Subscriber ID Number*

Also consider

- *Interior Zones by Area*
- *Enable Watch* (by Area)
- *Enable Fire Reset* (by Area)
- *Fire Areas*
- *Bus-2 Areas*
- *EZM PGM Armed Terminal Control*

### Arm Lug (Lug E4)

Lug E4 (ARM) will go to approximately 1Vdc when all areas in the system are armed. This lug may be used for auxiliary equipment. (For use, refer to the instructions furnished with the device.) The ARM Lug has been tested by UL for use with Napco's M7000-Series and M9000-Series Monitor™ dual-technology sensors in non-partitioned systems. Refer to WI464 and WI492, respectively, for installation. A maximum of 10 units can be connected a distance of up to 1000 feet using #22AWG wire.

**Auto Bell Test on Arming** (Required for UL Mercantile installations.)

This will activate the bell output briefly 10 seconds after the area is armed. If the alarm does not sound, the device may be defective.

**Auto-Bypass** (Do not program for UL installations.)

Zones programmed for *Auto-Bypass* will be bypassed (automatically removed) if in trouble when arming. A momentary beep will sound at the keypad to warn that the system has been armed without the protection of the auto-bypassed zone. (Note that the exit/entry door must be closed before arming, otherwise the Exit/Entry Zone will be auto-bypassed.)

**Note:** A zone in trouble that is not programmed for *Auto-Bypass* will cause an alarm on arming after a 10-second arming delay.

### Auto-Reset

#### Auto-Reset After Burglary Output Timeout

If a zone signals an alarm and is selected for *Auto-Reset*, it will automatically rearm itself as soon as the alarm condition is cleared. *Auto-Reset* may be delayed to occur after the Burglary Output timeout period by selecting *Auto-Reset After Burglary Output Timeout* and *Auto-Reset*. Zones 1 through 96 that are not programmed for *Auto-Reset* will not be capable of signalling another alarm until (a) the cause



of the alarm has been corrected and (b) the control panel is disarmed. Also see *Swinger Shutdown*.

**Auto-Reset Waterflow Zones** See *Waterflow*

**Auxiliary Relay** See *Alarm Outputs*

### Backup Report on Telco 2

If *Backup Reporting* is selected and the communicator does not reach the first telephone number after two attempts, seven attempts will be made to reach the second telephone number. Enter *Subscriber Identification Numbers* for Telephone 2 and other information required for Telephone 2. Also program *Backup Report on Telco 2*. Any zone programmed to report to Telco 1 will backup report to Telco 2. **Note:** Subscriber Identification Numbers for both Telephones 1 and 2 must be entered, even if they are the same.

### Battery

12Vdc standby power source in the control panel to provide backup protection in the event of a power loss. Napco's RBAT4 (optional) is rated at 4 ampere-hours, the RBAT6 (optional) at 6 ampere-hours. The battery is an integral part of the system and must be installed, even if ac power is present. Change the battery every 5 years or as required. **Note:** The Panel cannot be powered up from the battery alone. Also see *Low Battery*.

### Bell Control

In any system, the ability to silence any combination of alarm devices (relay outputs) initiated from any area. *Bell Control* must be programmed for all systems to be able to silence an alarm. For example, in a two-area system, each area could be programmed to silence only those alarms initiated within its own area; or both areas could be programmed to silence an alarm initiated from either area.

### Bell Cutoff with Waterflow Zone in Alarm

NFPA 72 requires that the bell sound so long as water is flowing in a Waterflow Zone. Programming this feature will allow the bell to be silenced upon entry of a valid User Code. Do not program this feature in UL installations.

### Burglary Lug (Lug E10)

Lug E10 (BURG.) will go to about 1Vdc when the Burglary Relay is tripped. This lug is intended for connection to UL-listed devices rated 5mA maximum and capable of operating over the voltage range of 8 to 13.0Vdc (12V, special application). Use Napco Harness Part No. WL2 for connection.

**Burglary Relay** See *Alarm Outputs*

### Bus-1 Failure

### Bus-2 Failure

Communication failure on the 4-wire burglary bus (Bus 1) will cause a system trouble condition and a report to the central station. Similarly, failure on the 4-wire fire bus (Bus 2) will initiate a system trouble condition and report. Program *System Trouble Reports* and Report Codes for Bus-1 and Bus-2 (if used).

### Bus 2 Area

The CF5530 module has provisions for a separate and independent bus (Bus 2) for wiring remote keypads, EZM3004/3008 modules, and RB3008 modules. Use of Bus 2 is not required by UL, but allows for a more secure

installation in that any failure on Bus 1 (e.g. ground fault, remote power shorted to ground, disconnected wires, tampering) will not affect devices on Bus 2 and will be immediately displayed at keypads on Bus 2 (and vice versa). This feature is especially convenient in partitioned combination Commercial Fire/Commercial Burglary installations, which require that a fire system be unaffected by a failure of the burglary system due to a bus failure. All keypads in a Bus-2 Area must be wired to Bus 2. The panel may be programmed so that all keypads and EZMs that are burglary related are on Bus 1 and all keypads and EZMs related to the fire system are on Bus 2.

**Call Waiting** See *Disable Call Waiting*

### Callback-Method Download

### Answering Machine Pickup Without Line Seizure

**Disable Callback Download** (Required for UL installations)

**Disable Answering Machine Download** (Required for UL installations)

### Disable Function-Mode Download

### Number of Rings Before Pickup

Data may be downloaded remotely to the panel after a programmed number of rings (3 to 15) and a control-panel confirmation callback. Program the number of rings in Location 3067 (if not programmed, the panel will pick up after 15 rings.)

This method will accommodate an answering machine at the site (line seizure must be used on the house phones unless *Answering Machine Pickup Without Line Seizure* is programmed). (Be sure that *Disable Answering Machine Download* is *not* programmed.) The answering machine will pick up on its programmed number of rings, as usual. The control panel will then listen for the signal from the PCD3000 software and seize the line from the house phones as well as the answering machine and the connection will subsequently be established. **Note:** The number of rings programmed into the panel must exceed that of the answering machine.

Program *Disable Callback Download* to prevent unauthorized downloading to an unattended panel. Program *Disable Answering Machine Download* to inhibit downloading to a telephone connected to an answering machine. Program *Disable Function-Mode Download* to prevent downloading at the keypad. These features must be programmed for UL installations. See *PROGRAMMING: Function Mode; Auto Download Method*.

**Cancel Next Test Timer Report on Any Report** See *Test Timer*

### Chime

This annunciator feature may be used on any zone to sound a tone at the keypad while disarmed when the zone goes into trouble. Access the *ACTIVATE CHIME* function to enable or disable the Chime Mode. This feature is programmable by zone and for duration of tone (see *Time Selection*). A time must be programmed for the chime to function.

### Clear Program

Wipes out the dealer program. To clear, access Location 3069 and press the [ON/OFF] Button.

## Closing Report

### Closing Only on Force Arm

#### Force Arm

#### Include Selective/Group Bypass In Force Arm/Status Status Report

On arming, the communicator can transmit a unique Closing Code for each user and a status report that identifies the problem zone to the central station. Note that *Subscriber Identification Numbers* and a Closing Code must be entered for any closing report.

Select which users will report closings for each telephone number, even if *Closing Only on Force Arm* is selected. Normally, a closing report will consist of the Closing Code and the number of the user that armed. If the user armed with an auto-bypassed zone (or selective/group bypassed zone if *Include Selective/Group Bypass In Force Arm/Status* was programmed), the *Force Arm Code* will also be sent. If a Force Arm Code is not to be sent, leave it blank.

Select *Closing Report Only on Force Arm* to report only when arming with an auto-bypassed zone (and selective/group-bypassed zone if *Include Selective/Group Bypass in Force Arm/Status* is programmed). This transmission will consist of a closing report followed by a *Force Arm Code*, or just a closing report if the Force Arm Code is blank.

Select *Status Report* to send a closing followed by a status report that identifies the problem zone(s). A typical Status Report is represented by the following example.

*Example (4/2 Format).* A burglar breaks into a commercial establishment during the night, breaking the window foil on Zone 5. The Open/Close Subscriber Identification Number is "1234"; the Alarm Code for Zone 5 is "3,5" (Burglary Zone 5); the Subscriber Identification Number is "6789"; the Closing Code is "C". The communicator will send the following report to the central station.

When alarm occurs:

"6789 35" – Alarm, Zone 5 (the same transmission would occur for Zones 15, 25, 35, etc.)

Closing Report:

"1234 C1" – Closing, User 1 (User 1 returned, inspected damage & rearmed; the same transmission would occur for User 11, 21, 31, etc.)

"1234 F5" – Trouble, Zone 5 (zone status at time of closing: Window foil still broken; Zone 5 auto-bypasses, repair required; the same transmission would occur for Zone 15, 25, 35, etc.)

## Data Format

Consult the central station to find out which of the following formats to use.

**Two-Digit or 4/2 Format.** Some central-station receivers require that a four-digit Account Code followed by a two-digit Alarm Code be sent in each report. *Example.* In a certain installation, the Alarm Subscriber Number is "1234"; a burglary alarm occurs on Zone 1. The Alarm Code for Zone 1 is "3,1". The communicator will send "1234 31" (Account No. 1234; Alarm, Zone 1).

**1400Hz Handshake/Kissoff.** 1400Hz Handshake overrides 2300Hz Handshake if both are selected.

**2300Hz Handshake/Kissoff.** Used with the following receiver formats: Radionics, DCI & Franklin Slow; Radionics Fast; Sescoa, Vertex, DCI & Franklin Fast; Radionics BFSK. 1400Hz Handshake overrides 2300Hz

Handshake if both are selected.

**Zone Number on Pulse Alarm.** If selected, an Alarm Code need not be programmed (the zone number will replace the Alarm Code), however codes for restore, trouble, etc. are still required. Thus, in the foregoing example, if "E" is the designated Restore Code, and Zone 96 trips and is restored, the communicator will send "1234 96" (Account No. 1234; Alarm, Zone 96) followed by "1234 E6" (Account No. 1234; Zone 96 Restored).

**Single-Digit Event Code Format.** The single digit sent for a particular event can be either the Event Code or one digit in the Alarm Code.

**Sum-Check Format.** Sum Check is a sophisticated data format used to enhance the speed and check the accuracy of the received transmission. This format should be preferred whenever the central station is capable of receiving it. After transmitting the Subscriber Identification Number and the Alarm Code, the communicator sends a verifying digit that is the sum of both. The receiver compares the verifying digit with the sum of the other numbers to check transmission accuracy.

**3/1 with Extended Restores.** Some receivers require a three-digit Account Code followed by a single-digit Alarm Code. *Example.* In another installation, the Alarm Subscriber Number is "123"; an alarm on Zone 1 is restored. The Restore Code for Zone 1 is "E,1". The communicator will send "123 E" (Account No. 123 Restored); followed by "EEE 1" (Restored, Zone 1).

**Modem Formats.** Modem formats (SIA, Point ID, Express, 4/3/1, Modem 2) are preset and automatic but require a type number for each zone. Program *Zone Type* as follows:

Fire – "1" (**Note:** Not for Modem 2 Receivers)

Panic – "2"

Burglary – "3"

Holdup – "4"

Fire Supervision – "5"

Fire Waterflow – "6"

Gas Alarm – "7"

Heat Alarm – "8"

Sprinkler Alarm – "9"

Auxiliary Alarm – "A"

**Pager Formats.** The control panel has provisions for dialing a pager phone number. The panel will wait for ringing, wait for silence, then send its data. *Caution:* Because there is no handshake/kissoff, *this feature should only be used for Double Reporting; it may not be used for Backup Reporting.* Only one report is sent for any call. Pager digits are limited to "0" through "9". Digits represented by "A" through "F" will be converted to "0"s for transmission purposes. Pager formats are 9 digits, arranged as illustrated by the following examples:

*Example 1.* 00 3 01 1234

Alarms, restores, etc. are transmitted in a 2-1-2-4 arrangement, where

00 = Pager ID (always two zeros);

3 = Report Code (programmable 0-9);

01 = Number of Zone Tripped (01-96);

1234 = Account Number (programmable).

Openings, closings, etc. are transmitted in a similar arrangement, where

- 00 = Pager ID (always two zeros);
- 3 = Report Code (programmable 0–9);
- 01 = User Number (01–99);
- 1234 = Account Number (programmable).

*Example 2.* 000 12 1234

Keypad Report Codes and System Report Codes are transmitted in a 3-2-4 arrangement, where

- 000 = Pager ID (always 3 zeros);
- 12 = Report Code (programmable 00–99);
- 1234 = Account Number (programmable).

**Compatible Receivers.** The following receivers are compatible with the MA3000.

- **FBI CP220.** *Formats:* Ademco Slow; Silent Knight Slow; Silent Knight Fast; SESCOA; Vertex; DCI; Franklin Slow; Franklin Fast; SIA; Radionics Slow; Radionics Fast; Radionics BFSK; FBI 4/3/1; Universal High Speed.
- **Ademco 685.** *Formats:* Ademco Slow; Silent Knight Slow; Silent Knight Fast; SESCOA; Vertex; DCI; Franklin Slow; Franklin Fast; Radionics Slow; Radionics Fast; Radionics BFSK; Universal High Speed; Ademco Point ID; Ademco Express.
- **Radionics 6500.** *Formats:* Ademco Slow; Silent Knight Slow; Silent Knight Fast; SESCOA; Vertex; DCI; Franklin Slow; Franklin Fast; Radionics Slow; Radionics Fast; Radionics BFSK; Universal High Speed; Radionics Modem 2.
- **Osborne-Hoffman Quickalert.** *Formats:* Ademco Slow; Silent Knight Slow; Silent Knight Fast; SESCOA; Vertex; DCI; Franklin Slow; Franklin Fast; SIA; Radionics Slow; Radionics BFSK; Universal High Speed; Ademco Point ID; Ademco Express.
- **Silent Knight 9000.** *Formats:* Ademco Slow; Silent Knight Slow; Silent Knight Fast; SESCOA; Vertex; DCI; Franklin Slow; Franklin Fast; Radionics Slow; Radionics Fast; Radionics BFSK; Universal High Speed; SIA.

**Day Zone**(Open; Short)

**Alarm on Day Zone**

**Disable Auto-Reset on Day Zone**

**Reset Day Zone with Arm/Disarm Only**

**Enable Watch, Area 1-8 (By Area)**

A *Day Zone* will give an audible and visual indication at the keypad if there is a problem on the loop while disarmed. Open- and short-circuit conditions are programmed separately, by zone. This feature may be used to warn of a problem (a break in a window foil, for example) during the day, when the panel is not normally armed. When the Day Zone is tripped, "DAY ZONE TRBL" and the zone number(s) will alternately display at the keypad and the sounder will pulse. Press the [RESET] Button to silence the sounder and reset the keypad. "ZONE FAULT" will be displayed until the condition is corrected. If *Reset Day Zone With Arm/Disarm Only* is programmed, arm and disarm the panel to reset the audible Day-Zone indication.

If *Alarm on Day Zone* is programmed for a zone, a Day Zone condition will cause the alarm outputs programmed for that zone (sirens, relays) to activate, but only once in any disarmed period.

**Note:** (1) If a zone is programmed for both *Day Zone Open* and *Day Zone Short*, either condition must be reset before the other can activate. (2) *Day Zone Short* will not function if *No EOL Resistor* is also programmed.

*Report Trouble* or *Trouble Restore* is programmed in

conjunction with *Day Zone Open/Day Zone Short* and *Trouble on Open/Trouble on Short* (the trouble reported will be that programmed under *Day Zone Open* and/or *Day Zone Short*).

**Note:** Do not program a Day Zone for 24-hour protection. The keypad will announce as a Day Zone but the panel will transmit an Alarm Code and a Trouble Code when tripped.

Program *Disable Auto-Reset on Day Zone* to prevent repeated Day-Zone trips. This will cause the keypad display and sounder to activate only once during any arm/disarm period.

If *Enable Watch* is selected (by area), zones programmed for Day Zone can only be activated when *ACTIVATE WATCH* is accessed. (See Section 3.) Arming and disarming will turn off the Watch Mode. If Report Trouble is selected, a trouble on a Day Zone will be reported only when the Watch Mode is on.

**Dealer Security Code** See *Master Security Code*

### Default Program, Burglary

The following Burglary default program will automatically be loaded on power-up.

- Exit Time: 60 seconds
- Entry Time 1: 30 seconds
- Entry Time 2: 30 seconds
- User 1 Code/Authority Level: 123/E3
- Priority: Zones 1–8
- Selective Bypass: Zones 1–8
- Burglary Relay: Zones 1–8; 15-minute timeout
- Exit/Entry: Zone 1
- Swinger Shutdown: Zones 1–8
- Area 1: Zones 1–8
- Fire Reset Enabled: Area 1
- Easy Bypass: Enabled
- Code Entry for Function Mode Level 1: Disabled
- Keypad 1: Area 1
- User 1 Code Enabled: Area 1
- Area 1 Turns Off Alarm: Area-1 Burglary Output; Area-1 Burglary-Pulse Output; Area-1 Fire Output

### Dial-Tone Detection

At least one *Dial-Tone Detection* entry is usually required for each telephone number used to ensure that a dial tone is present before the communicator dials.

When an "E" is programmed before the first digit of an outside telephone number, the communicator dial-tone detection circuit is set to detect the standard 440Hz dial tone. The "E" is generally entered in the location immediately preceding the telephone number.

It may be necessary to program at least one 4-second pre-dial delay before a dial-tone detection "E". With certain nonstandard exchanges, pre dial delay "D" may be used without a dial-tone detection "E". (See *Access Number for Outside Line; Pre-Dial Delay; Telephone Numbers*.)

### Digital Dialer Test

Activating the digital dialer test from the Function Menu (*COMM TEST TO CS, DIAGNOSTIC MENU*) will send the programmed report code to the central station. Program *DD TEST* for *SYSTEM-TROUBLE REPORTS* and enter a *DD TEST* Report Code. Note that in this case the report code received is not indicative of a system trouble, but is an

indication of a successful transmission. Should the transmission fail, the keypad will display "FAIL TO COMM". This system trouble may be reset by pressing the [RESET] Button. Any successful subsequent transmission will also clear the system trouble.

**Disable Answering Machine Download** See *Callback-Method Download*

**Disable Auto-Reset on Day Zone** See *Day Zone*

#### **Disable Auto Status**

Non 24-Hour Zones that are open (or shorted) normally display "ZONE FAULTS" at the keypad (while disarmed) followed by the zone number(s) and description(s). In high-security applications, program *Disable Auto Status*. Unsecured zones will then be indicated at the keypad by a "CHECK STATUS" display. Status may be displayed manually using the *DISPLAY STATUS* function, however a valid user code will be required.

#### **Disable Call Waiting (TouchTone® Dialing Only)**

A digital communicator connected to a telephone line with *Call Waiting* may be disrupted by this feature. However, most lines with *Call Waiting* also have *Selective Call Waiting*, which permits the feature to be turned off by dialing a "\*70" just before the telephone number. A "\*" will be dialed by programming a "B".

If the installation has the *Call Waiting* feature, be sure that it also has *Selective Call Waiting*, and confirm the disable code with the telephone company. Then program this code ("B70") directly before the phone numbers (after dial-tone detection or pre dial delay) in the telephone-number locations. See *Telephone Numbers*.

*Caution:* Should the user cancel his *Call Waiting* service, the communicator will dial a wrong number unless the phone number is corrected.

**Disable Callback Download** See *Callback-Method Download*

#### **Disable Code Entry for Function Mode Level 1**

Intended primarily for residential applications, this feature eliminates the user code requirement to access the Function Mode (for Level-1 Users only), rendering the system more user friendly.

#### **Disable Code Entry for Info Mode (Do not program in UL installations)**

Program this feature to eliminate the user code requirement to access the Info Mode (Fire Keypads only). (This is intended for keypads mounted inside a locked housing.)

**Disable Function-Mode Download** See *Callback-Method Download*

**Double Reporting** See *Report Telco 3*

#### **"E" Lugs (E3, E4, E5, E7, E9, E10, E11, E14, E18, E22)**

E4 - See *Arm Lug*

E9 - See *Fire Lug*

E10 - See *Burglary Lug*

E22 - Common terminal for Reset Relay.

Use Napco Harness Part No. WL2 for field wiring. (Lugs E3, E5, E7, E11, E14 and E18 are reserved for future applications.)

**Download Security Code** See *Master Security Code*

#### **Easy Arming**

Permits quick arming by simply pressing the [ON/OFF] Button. Each keypad may be individually programmed for *Easy Arming* (see *Keypad Features*). Disarming still requires entry of a valid user code. Do not program *Easy Arming* in UL installations. If closings are reported, *Easy Arming* will report as User 99.

**Enable Brownout Limits on Ac Failure** See *Ac Failure*

**Enable Easy Bypass** See *Selective Bypass* (Do not program in UL installations.)

#### **Enable Entry Warning Bell Chirp**

Causes the burglary bell to "chirp" if the entry door is opened within 60 seconds after exit time has elapsed. This feature may be useful in cases where a keypad is not within audible range to remind a user to disarm if inadvertently exiting after exit delay has expired.

**Enable Exit Delay Restart** See *Entry/Exit Delay*

#### **Enable Fire Reset (by Area)**

Program by area to use the Reset Relay to reset smoke detectors. Pressing the [RESET] Button will momentarily remove power to the smoke detectors. If *Enable Fire Reset* is selected for any area, do not use the Reset Relay for any other purpose. Also see *Alarm Outputs; Smoke Detectors*.

#### **Enable Ground-Fault Detection**

Should a short circuit to ground occur on any control-panel zone (1-8), a *GROUND FAULT* system trouble will display at the keypad with a pulsing sounder. Pressing the [RESET] Button will silence the sounder, however the "SYS TBL" reminder will continue to display. Correct the ground-fault condition to restore "system-ready" status. This condition may be programmed to activate an alarm, report to a central station (program *Panel Gnd-Fit Report Code*), or both.

#### **Enable Line-1 Fault Test**

#### **Enable Line-2 Fault Test**

#### **Telco Line Test Delay**

Programming *Enable Line-1 Fault Test* will cause the panel to monitor Telco 1. A failure will display at the keypad as "TELCO-1 FAIL". Program this system trouble to activate the Burglary Output, report to the central station, or both. If transmissions are unsuccessful on Line 1 and a second phone line is available, the panel will attempt to report via Line 2, otherwise a "FAIL TO COMMUNICATE" system trouble will be displayed.

Similarly, *Enable Line-2 Fault Test* will cause the panel to monitor Telco 2 (on the CF5530 Fire Board). A failure will display as "TELCO-2 FAIL" and the panel will attempt to report on Line 1.

If a time is entered in *Telco Line Test Delay*, Line 1 or Line 2 will be tested for the programmed duration before a system trouble is activated and/or reported. If locations are left blank, the delay time will default to 10 seconds.

**Enable Local Alarm on First Zone "AND" Trip** See *Zone ANDing* (Do not program in UL installations.)

#### **Enable Reporting to PCD3000**

This feature allows a PC computer with Quickloader Software to function as a receiver. If programmed, all alarms sent to Telephone No. 1 will be sent to *PC PRESET* as well (regardless of whether or not transmissions to

Telephone No. 1 were successful). *PC PRESET* must be in its standby mode for this feature to operate.

#### Enable Second Phone Line

Program to enable Telco 2 on the CF5530 Fire Board.

**Enable User Code by Area** See *User Codes/Authority Levels/Access Bytes*

#### Entry/Exit Delay

Entry/Exit 1; Entry/Exit 2

#### Enable Exit-Delay Restart

Delays permit exit and entry through the Entry/Exit Zone(s) after the system is armed without setting off an immediate alarm. Entry delay allows the user time to enter and disarm the panel. Exit delay allows the user to leave the premises after the panel has been armed. Unless the keypad has been configured otherwise, the keypad sounder will sound a pulsing tone (a) upon entry to remind the user to disarm; and (b) after arming to caution the user to exit quickly.

Two individually-programmable entry-delay times are provided to accommodate different entry zones (only one exit delay is provided). If two or more Exit/Entry Zones are entered in succession, the delay programmed for the last Exit/Entry Zone entered will take precedence over all others. Exit-Delay time and Entry-Delay time may each be programmed for up to 255 seconds (4¼ minutes). See *Time Selection*.

If the system has been armed with *Exit-Delay Restart* enabled, when the exit door is opened and then closed, the programmed exit delay will restart at 60 seconds. Thus, if a long exit delay is programmed, it will be reduced to 60 seconds after exiting, yet still allow reentry before entry time starts. If re-entry occurs within that 60 seconds, exit delay will restart once again (and *only* once again) at 60 seconds.

If re-entry occurs within 60 seconds after exit delay has expired, the alarm will sound a 2-second warning (in addition to the entry sounder) to remind the user to disarm. (*Exit-Delay Restart* may be useful in reducing false alarms caused by a user who re-enters the premises shortly after exiting.)

**Note:** In UL installations, Exit-Delay time may not exceed 60 seconds; Entry-Delay time may not exceed 45 seconds. In UL Mercantile installations, entry delay may not exceed 60 seconds.

Entry delay may be cancelled by pressing the [INSTANT] Button prior to arming, however it will be restored automatically upon disarming. (When armed with Instant protection, an "I" will appear at the right side of the display.)

#### Exit/Entry Follower

A zone programmed as an *Exit/Entry Follower* will ignore detection during the exit delay, and only during entry delay if the Exit/Entry Zone is entered first. Thus, detection devices (passive infrared detectors, for example) along the path between the keypad and the exit/entry door will not signal an alarm during exit/entry delay under normal conditions. However, if a device in the Exit/Entry Follower Zone detects a violation when the exit/entry door has *not* first been entered, there will be no entry delay and the Exit/Entry Follower Zone will go into an instant alarm.

If the panel is armed with the entry delays cancelled (Instant protection), any violation on the Exit/Entry Zone or the Exit/Entry Follower Zone will cause an immediate alarm.

#### Expansion Zones

##### EZM Type

##### EZM PGM Armed Terminal Control

EZM Tamper See *Tamper*

Zones 9 through 96 are termed *expansion zones*, zones added to the basic system using expansion zone modules (EZMs). Any combination of EZM3004 (4 zones), EZM3008 (8 zones) and/or the 4-zone modules integral to each RP3000LCD keypad may be used. Refer to *ADDING EXPANSION ZONES* in Section 2 and the *Wiring Diagram* at the back. Also see the instructions accompanying each EZM module for wiring information.

Regardless of how the modules are arranged, the expansion zones are divided into consecutively-numbered groups of four. Each 4-zone module comprises one group of zones; each 8-zone module comprises two groups. Each group is assigned a number.

For each EZM group, program an *EZM Type*, as follows. **Note:** *EZM Type* addresses consist of two *nibbles*: left and right.

*EZM Not Used:* leave both nibbles blank (••)

*Burglary EZM:* enter "1" in the right nibble (•1).

*Bus-2 Burg EZM:* enter "8" in the left nibble and "1" in the right nibble (82).

If *EZM PGM Armed Terminal Control* is programmed for the EZM module, Terminal 6 on the module will go low when the areas programmed for that module are armed. This may be used to display *area armed* status on an external LED (for example). **Note:** (1) This terminal is intended for connection to UL-listed devices rated 5mA maximum and capable of operating over the voltage range 8.0–13.0Vdc (12V, special application). (2) In two-group modules (EZM3008), only the lower of the two groups may be programmed.

**Extended Format** See *Data Format*

#### Fire

##### Keypad Fire

Any zone may be programmed for *Fire*. Connect normally-open devices across a Fire Zone. (The EOL2.2K end-of-line resistor must be installed.) A short across the zone will cause a fire alarm, which will be indicated by a steady-on red LED and a pulsing keypad sounder. An open circuit on the Fire Zone will identify a trouble and cause flashing red LED and pulsing sounder after a 10-second delay. The sounder may be silenced using the [RESET] Button. The LED will go off within 30 seconds after reset if the alarm or trouble is cleared. For Smoke-Detector Reset, see *Alarm Outputs*.

If *Keypad Fire* is programmed, pressing both [F] and [\*] keypad buttons at the same time will sound a fire panic alarm and display "\*\*\*\*\*FIRE\*\*\*\*\*" at the keypad. The Keypad Fire function is supplementary to the hardwired zones. **Note:** This feature shall not be considered a substitute for listed manual initiating devices.

##### Fire Area

All zones in a Fire Area must be programmed as Fire Zones. All keypads in a Fire Area should be Fire ("CF") Keypads. (Do not intermix Burglary and Fire keypads in the same area.)

##### Fire Lug (Lug E9)

Lug E9 (FIRE) will go to about 1Vdc when the Fire Relay is

tripped. This lug is intended for connection to UL-listed devices rated 5mA maximum and capable of operating over the voltage range 8.0–13.0Vdc (12V, special application).

**Fire Relay** See *Alarm Outputs*

**Force Arm** See *Closing Report*

**Interior Zones by Area** (Interior 1/Interior 2)

**Interior 1 Normally Bypassed**

Removal of a programmed group of interior zones from the system will permit freedom of movement throughout the premises but still afford protection from intrusion through armed perimeter zones. Two groups of zones may be programmed for any area; either or both may be selected.

Pressing the [INTERIOR] Button prior to arming will select between Interior 1 (I1), Interior 2 (I2) or both (INTERIORS I1 + I2). Select, then arm to bypass. The next time the control panel is disarmed, all bypassed zones will automatically revert to non-bypassed (disarmed) zones.

If interior zones are bypassed, the "BYPASS" reminder on the RP3000LCD will display. The bypassed zones may be displayed on the keypad (see *RP3000LCD FUNCTION MODE*).

If *Interior 1 Normally Bypassed* is selected, all Interior-1 Zones will always be inactive. The "BYPASS" reminder will always display, indicating that only partial protection will be provided upon arming. To temporarily restore interior protection, press the [INTERIOR] Button; the "BYPASS" reminder will go out upon arming, denoting full protection. However Interior 1 Zones will once again be bypassed the next time the panel is disarmed.

**Include Selective/Group Bypass In Force Arm/Status**  
See *Closing Report*

**Interior 1 Normally Bypassed** See *Interior Zones by Area*

**Jumpers** (Refer to *Wiring Diagram* for UL configuration.)

- A: Cut for dry contacts on the Auxiliary Relay.
- B: Cut for dry contacts on the Burglary Relay.
- C: Cut for dry contacts on the Reset Relay.
- F: Cut for dry contacts on the Fire Relay.

**J5:** Keypad Configuration jumper block. Jumper is installed across top and center pins for normal operation. When configuring keypads, move jumper across center and lower pins.

**Keypad Jumpers.** These are mounted at the right side of the keypad circuit board (as viewed from the front) and are listed in order from top to bottom.

- JP1: Cut to enable Keypad Tamper.
- W1: Reserved - *do not cut!* (See *W1 & W3*, below.)
- W2: Cut to disable LCD backlighting.
- W1 & W3: Cut to disable touchpad backlighting.

**Keypad Area Assignments**

In multiple-area systems, assign an Area Number ("1" through "8") to each keypad. Note that each address comprises 2 nibbles; enter the *Area Number* in the *right* nibble. If the keypad is a Fire Keypad, also program a "4" in the *left* nibble.

**Keypad Features**

The following programmed system features will activate

only if they have also been enabled at the keypad.

- Ambush
- Easy Arming
- Access Control
- Tour Station
- Keypad (Police) Panic
- Keypad Auxiliary Panic
- Keypad Fire Panic

**Keypad Panic** See *Panic Zone*

**Keypad Tamper** See *Tamper*

**Line-Reversal Module, M278**

The Line-Reversal Module allows the control panel to be monitored by a central station through leased lines. On alarm, the module reverses normal line-voltage polarity. For details, refer to the instructions furnished with the module.

**Loop Response** (750mS required for UL installations)

Loop response is the amount of time in milliseconds (mS) that a normally-closed circuit must remain open, or a normally-open circuit must remain closed, to trigger an alarm. The slower the loop response, the more immune the system will be to intermittents ("swingers"). Loop response times for Zones 1 through 8 are programmed into the control panel; those for Zones 9 through 96 are selected at the respective keypad or expansion module. (Refer to keypad instructions and EZM Installation Instructions.)

Selectable loop-response times for Zones 1–8 are:

**750mS (.75 sec.):** The slowest loop-response time, recommended for use with magnetic contacts, window foil, etc. Unless programmed otherwise, loop-response time will be 750mS for all zones.

**50mS (.05 sec.):** Used for momentary Panic Buttons and area-protection devices, such as photoelectric eyes, passive infrared sensors, floor mats, etc.

**10mS (.01 sec.):** An extremely fast loop response used primarily for window bugs.

**Low Battery** (Required for UL Mercantile installations)

A low-battery alarm will signal when the battery terminal voltage drops to 11.0V, nominally. This condition may signal a local sounding device, report to a central station (program *Panel Low Bat Report Code*), or both. A *low-battery* condition is interpreted differently from a *no-battery* condition, although either will initiate a *LOW BATTERY* system trouble. If there is no battery in the system, a restore will occur when the output relays are activated. If a battery is installed and low terminal voltage is detected, a restore will not occur until the battery is recharged to its specified level and passes a dynamic test, i.e., under load with charging circuit removed. The dynamic test may be initiated manually by pressing the [RESET] Button, or it will be initiated automatically, every four hours, by the panel.

Should its terminal voltage drop below 9.0 volts (nominally), as after a lengthy power failure, the battery will automatically be removed from the system in an effort to prevent overdischarging and possible irreversible battery damage. However, it will continue to supply power for RAM, in addition to a large memory-backup capacitor, to maintain system integrity.

**Master Security Code**  
**Dealer Security Code**  
**Download Security Code**

The factory-programmed *Master Security Code* (printed on the label affixed to the micro can) is unique and cannot be changed. Use this code to enter the Program-2 Mode (Dealer Program Mode) to program (or change) the *Dealer Security Code*. If a Dealer Security Code is programmed, both the Dealer Security Code and the Master Security Code will work. However, should system RAM fail, only the Master Security Code will work.

The Dealer Security Code is required to enter the Program 2 Mode, thus allowing the dealer to program codes, exit/entry times, zone features, reporting features and zone descriptions (see Section 4). This code may be changed as required.

*Important!* If the label containing the Master Security Code will be removed, the code must be recorded in a secure place for reference, as programming changes cannot be made without it (or the Dealer Security Code).

To change the Dealer Security Code, access the *PROGRAM 2* Mode. Advance to the "PROG" screen, then change the 6-digit code as required. **Note:** If the Dealer Program Code is entered within the first three minutes of power-up and a communication is in progress, the transmission will terminate.

The *Download Security Code* is the six-digit code required to establish connection to the PCD3000 Quickloader Software.

**Memory Failure**

A User or Dealer Memory error will cause the sounder to pulse, the "SYS TBL" reminder to flash, and the display to read "SYSTEM TROUBLE", then "ERROR USER MEM" (or "ERROR DEALER MEM"). Press the [RESET] Button to silence the sounder ("CHECK TROUBLE" will display, along with the "SYS TBL" reminder). Activate *RESET SYSTEM TROUBLE* (RESET MENU) to manually reset the system trouble. A Memory Failure can be programmed to activate an alarm output and/or report using its associated system Report Code.

**Never Arm** (May not be used for primary Burglary protection)

A zone programmed as *Never Arm* cannot go into alarm. If tripped, it will display at the keypad when the *DISPLAY STATUS* function is selected. A chime will sound at the keypad while armed or disarmed if *Chime* is also programmed for that zone, and enabled. This feature is suggested for use as a garage-door or driveway monitor, or similar application.

**No EOL Resistor**

Program for any zone not wired with a 2200Ω end-of-line resistor (Napco Part No. EOL2.2K). This will disable any short-circuit indication (if programmed, *Day Zone Short* is disabled). If not programmed, an end-of-line resistor must be installed. **Note:** This selection is automatically disabled for zones selected as *Fire*.

**Number of Rings Before Pickup** See *Callback-Method Download*

**One-Button Arming** See *Easy Arming*

**Opening Report**

**Opening Report Only After Alarm Report** (Do not program for UL installations)

Opening and closing reports are generally used in commercial installations. On disarming, the communicator can send an Opening Code for Users 1-96 (*Opening Report*), or it may transmit only when the control panel is disarmed after an alarm has been reported (*Opening Report Only After Alarm Report*). Note that Subscriber Identification Numbers and Opening Codes must be entered for either opening report.

Program *Opening Report Only After Alarm Report* to report only when disarming after an alarm report. This feature may be used by the central station to verify that the subscriber has responded and disarmed the panel. If *Opening Report Only After Alarm Report* is selected, also select *Opening Report* for each user.

**Panic Zone**

**Keypad Aux Panic**

**Keypad (Police) Panic**

**Keypad Fire Panic** See *Fire*

The *Panic Zone* is always a 24-Hour Zone. Each keypad is individually selectable for keypad panics (see *Keypad Features*). If *Keypad Panic* is programmed for a keypad, police panic is activated by simultaneously pressing the [P] and [\*] Buttons. If *Keypad Aux.* is programmed, pressing [A] and [\*] Buttons simultaneously will trip an auxiliary emergency alarm. If *Keypad Fire* is programmed, pressing [F] and [\*] at the same time will activate fire panic.

**Power-Up Delay**

If programmed, power-up will be delayed for 5 minutes to allow devices such as PIRs sufficient time to reset (warm up).

**Pre-Alarm Warning**

Programmable by zone, this feature will cause an alarm condition to sound only at the keypad for the duration of the programmed abort delay (see *Abort Delay; Time Selection*). After the abort delay has elapsed, the alarm output will activate and a report will be initiated.

**Pre-Dial Delay**

A *Pre-Dial Delay* may be used whenever a delay is required before dialing. It may be required when programming *Dial-Tone Detection*, which causes the communicator to wait before it attempts to detect a dial tone (see *Dial-Tone Detection*). Certain telephone exchanges send a nonstandard dial tone that the communicator may not be able to detect. With these nonstandard exchanges, it is possible to program *Pre-Dial Delay* rather than *Dial-Tone Detection*. This will cause the communicator to wait for a predetermined period of time before dialing rather than look for a nonstandard dial tone.

Contact the telephone-equipment supplier to find out how long a delay is required before dialing. Select *Pre-Dial Delay* by programming one "D" for each 4-second delay required immediately before the telephone number. **Note:** In UL installations, do not program more than one "D" before the telephone number.

See *Backup Report on Telco 2; Report Telco 3 (Double or Split Reporting)*. Also see *Access Number for Outside Line; Telephone Numbers*.

**Priority Zone** (Required for all zones in UL installations.)

A zone that will prevent arming if in trouble. If an attempt is made to arm, the sounder will come on and a "PRIORITY TROUBLE" will be displayed for 4 seconds. The RP3000LCD keypad may be reset by simply pressing the [ON/OFF] Button. The problem on a Priority Zone must be corrected before the panel can be armed.

Any zone may be selected as a *Priority Zone*. A zone in trouble that is neither a *Priority Zone* nor an *Auto-Bypass Zone* will cause an alarm on arming.

**Priority Zone with Bypass**

A Priority Zone that will permit arming if the priority condition is bypassed. If the system is so programmed, the zone will auto-bypass and (optional) the condition will be reported to a central station.

As above, if an attempt is made to arm, the sounder will come on and a "PRIORITY TROUBLE" will be displayed. To reset the keypad, enter a User Code, or simply press the [ON/OFF] Button; the display will read "CHECK STATUS". To arm the panel, press the [RESET] Button, then enter the User Code.

Any zone not selected as a *Priority Zone* may be programmed as a *Priority Zone with Bypass*. If selecting *Priority Zone with Bypass*, *Auto-Bypass* is selected automatically. See *Auto-Bypass; Closing Report Only on Force Arm*.

**Pulse Burglary Relay** See *Alarm Outputs*

**Receiver Format**

The communicator can be programmed to transmit to any standard central-station receiver. A receiver format must be entered for each telephone number used, but a different format may be assigned to each.

Refer to *Backup Report on Telco 2* and *Report Telco 3* to determine whether or not Telephones 2 and/or 3 will be programmed. Call the central station for each telephone number used to confirm the type of receiver in use. Select the receiver format entry for each telephone number from the following table.

ENTRY	RECEIVER FORMAT	DATA FREQ. (HZ)	DUTY CYCLE (ON/OFF)	INTER-DIGIT TIME
(blank)	Ademco, Silent Knight Slow	1900	60/40mS	600mS
1	Sescoa, Vertex, DCI, Franklin Fast	1800	30/20	800
2	Radionics Fast	1850	13/12	400
3	Silent Knight Fast	1900	40/30	560
4	Radionics, DCI, Franklin Slow	1800	60/40	600
5	Universal Hi-Speed	1850	30/20	350
8	Radionics BFSK			
9	4/3/1*			
A	Radionics Modem 2*			
B	SIA*			
C	Point ID*	Modern formats		
D	Express (TouchTone 4/2 format)			

\*These formats do not use programmable codes, but Event ID Codes to identify the type of zone as follows:

- 1 – Fire
- 2 – Panic
- 3 – Burglary
- 4 – Holdup
- 5 – Fire Supervision
- 6 – Fire Waterflow
- 7 – Gas Alarm
- 8 – Heat Alarm
- 9 – Sprinkler Alarm
- A – Auxiliary Alarm

**Relay Outputs** See *Alarm Outputs*

**Remote Access** See *Access Control on Auxiliary Relay*

**Remote Relay Control**

Besides the four relays provided on the motherboard, additional relays can be controlled from the keypad through the use of RB3008 (Relay Board) and RM3008 (Relay Module) options. Each model contains 8 relays. The RB3008 mounts within the control-panel enclosure; the RM3008 is designed for external remote mounting. Eight units (either 1 RB3008 + 7 RM3008s or 8 RM3008s) will provide a total of up to 64 relays.

For each relay, program four 2-nibble address locations as detailed in the Keypad Programming Workbook.

*1st Location (XXX1):* Program the areas having the ability to shut off the relay. Program Areas 5-8 in the left nibble; Areas 1-4 in the right nibble.

*2nd Location (XXX2):* Program relay timeout. The left nibble has a time factor of 16; the right a time factor of 1 (also see *Time Selection*). If timeout units are in minutes (see 4th Location), maximum programmable time is 4¼ hours; if timeout units are in seconds, 4¼ minutes. **Note:** Program a minimum timeout of 3 seconds.

*3rd Location (XXX3):* Enter an Event ID Code. A list of Event ID Codes is provided at the back of the Keypad Programming Workbook.

*4th Location (XXX4):* Left nibble, program (a) *Zone Type* and (b) *Timeout Units* as follows.

(a) Select *Zone Type* (Leave blank for Burglary Zone):  
 "1" = Fire; "2" = Waterflow; "3" = Sprinkler Supervisory; "4" = Day Zone.

(b) If relay timeout will be in seconds, add "8" to *Zone Type* (a) above. Otherwise, relay timeout will be in minutes.

*4th Location (XXX4):* Right nibble, program *type of activation* as follows:

"1" = Alarm; "2" = Restore; "3" = Trouble; "4" = Trouble Restore. (Leave blank if relay is not used.)

**Report Telco 1**

**Report Telco 3** (Double or Split Reporting)

Alarms, alarm restores, troubles and trouble restores may be selected individually for each zone. Violation of a zone selected to report will communicate the code(s) selected for that zone to the central station.

Normally, *Report Telco 1* is used to report to the central station. *Report Telco 3* is used when certain zones will report to a different receiver (split reporting); *Report Telco 1* and *Report Telco 3* are both used on the same zone to report to two receivers successively (Double Reporting). Also see *Backup Report on Telco 2*.

**Reset Day Zone with Arm/Disarm Only** See *Day Zone*



**Reset Relay See Alarm Outputs**

**Selective Bypass**

**Enable Easy Bypass (Not for UL installations.)**

Removal of one particular zone from the system. Any or all Zones 1-96 programmed for selective bypass may be removed from the system, but each must be removed separately. Refer to *RYPASSING ZONES* in Section 3 for operation.

Programming *Enable Easy Bypass* will permit bypassing without code entry. Do not program this feature in high-security applications.

When one or more zones is bypassed, the "BYPASS" reminder on the RP3000LCD keypad will display.

**Sensor Watch™**

Program for any zone containing a PIR or dual-technology sensor, floor mats, door contacts, or other device where some activity is expected. This feature supervises the sensor by verifying that the zone activates before the PIR timer runs out. If no trip is detected within the programmed *Sensor-Watch* time, a system trouble will result and "ACTIVITY FAILURE" will be displayed at the keypad, followed by the zone number(s). Select *RESET SENSOR MSG* function (RESET MENU) to reset this system trouble.

Program the Sensor-Watch PIR timer in Location 3066. Select a value in accordance with the anticipated activity within the coverage area while disarmed. In calculating the Sensor-Watch time, note that only the disarmed days (the time between armed periods) are added. In moderate traffic areas, a Sensor-Watch time of perhaps 1 day may be appropriate, whereas in remote areas, a time of 7 days or more may be in order. Supervision time should be calculated for the supervised zone with the least amount of traffic. Up to 255 days may be programmed (see *Time Selection*).

**Single-Digit Format See Data Format**

**Smoke Detectors**

Connect smoke detectors as shown in the following diagrams. The normally-closed contacts of the Reset Relay are used to reset the smoke detectors.

**Two-Wire Smoke Detectors.** Two-wire smoke detectors may only be used only on Zones 1-8. Up to 10 compatible 2-wire smoke detectors may be wired to each zone. To install 2-wire smokes, proceed as follows:

1. Program the selected zone(s) (1-8) for *2-Wire Smoke Detectors* and *Fire*. In Residential applications, program *Pulse Burg Output*. In Commercial Fire applications the supervised fire relay is enabled. Program *Enable Fire Reset* in the applicable area(s).

2. Cut out the 2700Ω resistor (color code, red/violet/red) associated with the selected zone(s). See following table.

ZONE	RESISTOR	LOCATION ON BOARD
1	R1	ABOVE TERMINAL 21
2	R2	ABOVE TERMINAL 23
3	R3	ABOVE TERMINAL 24
4	R4	ABOVE TERMINAL 25
5	R5	ABOVE TERMINAL 26
6	R6	ABOVE TERMINAL 29 (LEFT)
7	R7	ABOVE TERMINAL 29 (RIGHT)
8	R8	ABOVE TERMINAL 31

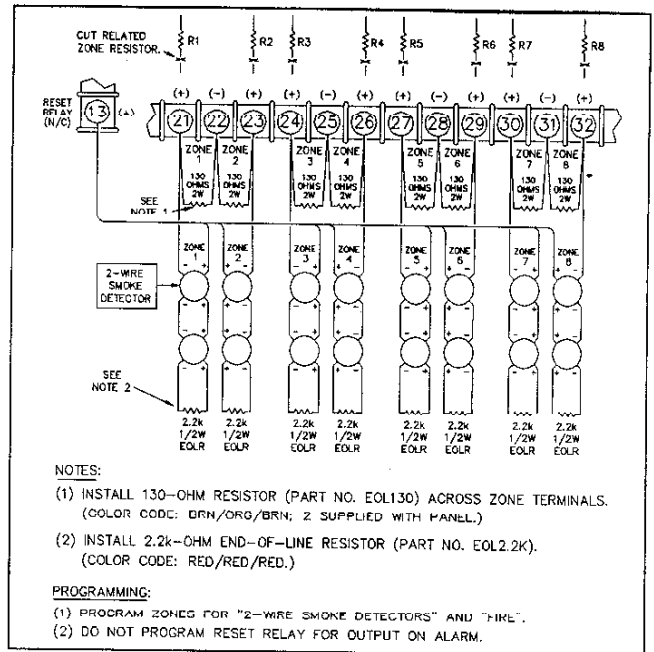

**Wiring diagram for two-wire smoke detectors.**

3. Referring to the Wiring Diagram, install a 130Ω resistor (Napco Part No. EOL130; color code: brown/orange/brown), 3 watts, across the two terminals of each selected zone.

4. Wire the positive (+) terminal of the smoke detector to Terminal 13. Wire the negative (-) terminal of the smoke detector to the positive terminal (+) of the zone.

**Four-Wire Smokes.** If installing 4-wire smokes, subtract smoke-detector alarm current from available standby current. See *COMPATIBLE UL-LISTED DEVICES*.

Program each zone for *Fire*. Also program *Fire Output* or *Pulse Burg. Output* and *Enable Fire Reset* in the applicable area(s). If they are of the self-resetting type, 4-wire smokes may be powered from Terminal 15 (+ AUX. PWR.) instead of Terminal 13, thus freeing the Reset Relay for other uses.

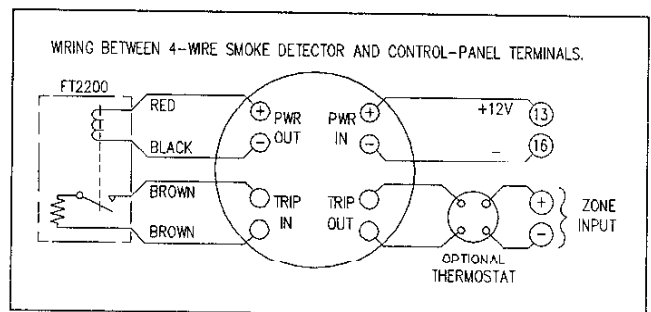

**Wiring diagram, four-wire smoke detectors.**

**Split Reporting See Report Telco 3**

**Sprinkler Supervisory**

A *Sprinkler Supervisory Zone* is normally used for sprinkler supervisory devices such as water shutoff valves and devices that monitor tank water level, air and water pressure, water temperature or similar conditions to ensure the normal operation of an automatic sprinkler system. This loop requires normally-open contacts with an end-of-line resistor. A short on the zone will cause a *Sprinkler Super-*

visory Alarm indication; an open will cause a *Sprinkler Supervisory Trouble* indication.

**Note:** A zone programmed as *Sprinkler Supervisory* must be programmed as a *Fire Zone* as well.

### **Start Exit Delay After Ringback**

When a closing report is successfully received, the central station will acknowledge by returning a kissoff signal. When the kissoff is received by the communicator, a 2-second ringback tone will sound at the panel. *Start Exit Delay After Ringback* will cause the exit delay to start after the ringback sounds.

If this option is chosen and no ringback sounds shortly after the control panel is armed, exit delay will not start and opening the exit/entry door will cause an instant alarm. To manually start the exit delay, select the *START EXIT TIME* function (RESET MENU), then press the [ON/OFF] Button to execute.

**Note:** (1) If this feature is selected, Exit/Entry Follower Zones will not arm until either a ringback sounds or the *START EXIT TIME* function is used. (2) If communicator, telephone lines or central-station receiver is out of service, the system will be armed without communication capability.

**Status Report** See *Closing Report*

### **Subscriber Identification Numbers**

If reporting openings and/or closings, program *Subscriber Opening/Closing Identification Numbers* for each area for each telephone number used. If reporting events, program Subscriber ID Numbers for each area for each telephone number used. Subscriber ID numbers must be programmed for each area and telephone number, even if all are the same. Start with the left-most location.

**Sum Check** See *Data Format*

**Suppress "BYPASS" Reminder When Armed** (Must be enabled in all UL systems)

Program to inhibit the LCD "BYPASS" display while armed.

**Swinger Shutdown** (Do not program for UL Installations.)

Program for zones with *Auto-Reset* to only reset twice (3 alarms) until rearmed to prevent "swingers" (intermittents) from causing repeated false alarms. See *Auto-Reset*. The *Swinger-Shutdown* feature is programmable by zone, but is not applicable to Ambush.

### **System Trouble Reports** (Global and Area)

*Global* system troubles may be programmed to report to any telephone number and/or activate the Burglary Output. *Area* system troubles may be programmed to report to any telephone number and/or activate any output. Also program *Subscriber ID Numbers*, *Telephone Numbers*, and *Report Codes* for each system trouble.

### **Tamper**

#### **EZM Tamper**

#### **Keypad Tamper**

Removing the cover of an expansion zone module will cause the sounder to pulse and the "SYS TBL" reminder to flash. The keypad will display "SYSTEM TROUBLE" then "TAMPER EZM XX", where "XX" denotes the module number. Press the [RESET] Button to silence the sounder ("CHECK TROUBLE" will display). Correct the problem, then select *RESET SYSTEM TBL* (RESET MENU) to manually reset the

system trouble display.

Removing a keypad from the wall will cause a similar system trouble indication. The keypad will display "SYSTEM TROUBLE" then "TAMPER KEYPAD XX", where "XX" denotes the keypad number. Press the [RESET] Button to silence the sounder ("CHECK TROUBLE" will display). To manually reset the system trouble, correct the problem then select *RESET SYSTEM TBL* (RESET MENU).

A Tamper condition can be programmed to activate an alarm output and/or report using its associated system Report Code.

**Telco-1 Fail; Telco-2 Fail** See *Enable Line-1 (-2) Fault Test*

**Telco Line Test Delay** See *Enable Line-1 Fault Test; Time Selection*.

### **Telephone Numbers**

To report to a central station, *Telephone Number 1* must be programmed. *Telephone Number 2* is programmed for Backup Reporting; *Telephone Number 3* is programmed for Double or Split Reporting.

Private telephone systems may require a *Dial-Tone Detection "E"* or *Pre-Dial Delay "D"*, followed by an access number to obtain an outside line. (See *Access Number for Outside Line*.)

It should be noted here that the telephone number need not actually start in the first location shown, and may not end in the last. Extra locations have been provided to allow for one or more prefix digits: a *Pre-Dial Delay "D"* or a *Dial-Tone Detection "E"*. What is important is that the telephone number, with its associated *Pre-Dial Delay*, *Access Number*, and *Dial-Tone Detection*, be wholly contained within that group of locations, and that they be in their proper sequence.

### **Test Timer**

#### **Cancel Next Test Timer Report on Any Report**

The test timer schedule is programmed using Napco's PCD3000 Quickloader Software. If *Test Timer* is programmed, an automatic test report will be transmitted to the central station on the scheduled day(s) at the scheduled time. (UL installations require a report at least every 24 hours.) To report test timer, select *Report Test Timer* and program a report code. Program the *Test Timer* event schedule and reporting time.

If *Cancel Next Test Timer Report on Any Report* is programmed, any report will cause the next test-timer transmission to be aborted, however subsequent test-timer transmissions will report as scheduled. Do not program this feature in UL installations.

### **Timeout**

Specifies the length of time that an alarm, alert, or delay will remain active. *Relay Output 2 Access Control Time*, *Abort-Delay Time*, and *Chime Time* must be programmed, or the feature will not activate. See *Time Selection*.

### **Time Selection**

The following times are programmable:

TIME <sup>(1)</sup>	UNITS	MAX. PROGRAMMABLE TIME
RESET RELAY	MIN.	UNTIMED <sup>(2)</sup>
AUXILIARY RELAY	MIN.	UNTIMED <sup>(2)</sup>
AUXILIARY RELAY ACCESS CONTROL	SEC.	4 MIN, 15 SEC (255 SEC)
BURGLARY RELAY	MIN.	UNTIMED <sup>(1)(2)</sup>
PULSE-BURG RELAY	MIN.	UNTIMED <sup>(1)(2)</sup>
FIRE RELAY	MIN.	UNTIMED <sup>(2)</sup>
ABORT DELAY	SEC.	4 MIN, 15 SEC (255 SEC) <sup>(3)</sup>
CHIME TIME	SEC.	4 MIN, 15 SEC (255 SEC) <sup>(3)</sup>
AC-FAIL REPORT DELAY	2 MIN.	8 HR, 30 MIN (510 MIN)
EXIT DELAY	SEC.	4 MIN, 15 SEC (255 SEC) <sup>(4)</sup>
ENTRY DELAY 1	SEC.	4 MIN, 15 SEC (255 SEC) <sup>(4)</sup>
ENTRY DELAY 2	SEC.	4 MIN, 15 SEC (255 SEC) <sup>(4)</sup>
CF5530 SPVSRV RELAY	SEC.	4 MIN, 15 SEC (255 SEC)
CF5530 RELAY 1	MIN.	4 HR, 15 MIN (255 MIN)
CF5530 RELAY 2	MIN.	4 HR, 15 MIN (255 MIN)
WATERFLOW DELAY	SEC.	2 MIN (120 SEC) <sup>(5)</sup>
PRESIGNAL DELAY	MIN.	4 MIN, 15 SEC (255 SEC)
TELCO LINE-TEST DLY	SEC.	4 MIN, 15 SEC (255 SEC) <sup>(6)</sup>
GUARD-TOUR PERIOD	MIN.	4 MIN, 15 SEC (255 SEC)
SENSOR-WATCH TIME	DIS-ARMED DAYS	255 DAYS <sup>(7)</sup>

**NOTES:** (1) The output used for Burglary must be at least 4 minutes in Residential UL installations, 15 minutes in Commercial UL installations. (2) If both locations are left blank, this feature will remain active until the system is disarmed. When both locations are programmed "F", maximum time will be 4 hours, 15 minutes (255 minutes). (3) If both locations are left blank, this feature will not activate (timeout = 0). (4) In UL installations: Maximum Exit Delay = 60 sec; Maximum Entry Delay = 45 sec. (5) Do not program for more than 120 seconds. If using waterflow initiating devices having mechanical delay, UL requires that these locations be left blank to prevent programming additional delay time. (6) If programming locations are left blank, delay will default to 10 sec. (7) Time in units of disarmed days (accumulated between armed periods).

Any timeout up to those shown in the foregoing table may be programmed. Note that each of the above times is programmed in two locations. The first location has an assigned time factor of 16, the second a time factor of 1.

1st BOX	2nd BOX
tx16	tx1

Time t:	0	1	2	3	4	5	6	7	8	9	10	11	12	13	14	15
Entry:	*	1	2	3	4	5	6	7	8	9	0	B	C	D	E	F

\*Blank.

**Note:** If both programming locations are left blank, refer to the notes in the *Time Selection* table for feature timeout.

To select a time up to 15 seconds, 15 minutes, 15 hours, or 15 days, program the respective entry into the second box only; do not program the first box. To select a time greater than 15 seconds, 15 minutes, 15 hours or 15 days, program both boxes as follows:

1. For the feature selected, choose an appropriate time in units shown (all seconds, minutes, hours, or days — not minutes and seconds, etc.).
2. Divide the time chosen by 16. Enter the *quotient* in the 1st BOX and the *remainder* in the 2nd BOX.
3. Check entries by adding the contents of the 2nd BOX

to 16 times the contents of the 1st BOX. (Remember that a "zero" entry represents 10.)

*Example.* Program *Entry Delay 1* for 1½ minutes.

1. *Entry Delay 1* is in units of seconds, thus delay time is 90 seconds.

2. Divide by 16:  $90/16 = 5$  (quotient) + 10 (remainder). Enter the *quotient* in the 1st BOX and the *remainder* in the 2nd BOX:

1st BOX	2nd BOX
5	0
quotient	remainder
	("0" for 10)

3. Check entries (remember, a "0" entry = 10):  $(16 \times 5) + 10 = 90$ .

### TouchTone Dialing Only TouchTone Dialing with Rotary Backup

Select *TouchTone Dialing Only* if the subscriber has TouchTone service. TouchTone dialing is faster than rotary dialing, but not always as reliable.

For the communicator to use TouchTone on all dial attempts, program *TouchTone Dialing Only*. To use TouchTone on the first attempt with subsequent Rotary dial, program *TouchTone Dialing with Rotary Backup*. *TouchTone Dialing Only* will override *TouchTone Dialing with Rotary Backup* if both are selected. Note that if Backup Reporting is also selected, the communicator will use rotary dial to reach Telephone 2. See *Backup Report on Telco 2*.

### Tour Station See Guard Tour

### Trouble

An abnormal zone condition (a break in a normally-closed loop; a short on a normally-open loop; or either on an end-of-line-resistor supervised loop) when disarmed.

Trouble on a Burglary Zone is automatically displayed at the keypad unless *Disable Auto Status* is programmed. If a Burglary Zone is in trouble, it will go into alarm about 10 seconds after arming. However, if *Auto Bypass* is programmed, the keypad will beep upon arming (does not apply to selective- or group-bypassed zones).

Trouble (open and/or short circuit) on a Day Zone is indicated by a flashing green STATUS LED and a pulsing sounder; display the Day Zone(s) in trouble on the LCD. Keypad indications are reset by the [RESET] Button unless *Reset Day Zone With Arm/Disarm* is selected.

Trouble on a Fire Zone will be indicated by the red LED and the sounder. An open circuit (trouble) will cause a flashing LED and a pulsing sounder after a 15-second delay. (A short circuit will cause an alarm condition: steady-on LED and pulsing sounder.) The [RESET] Button will silence the sounder. Clear the trouble, then press the [RESET] Button once again. The keypad will reset after a brief delay.

### Trouble on Open

### Trouble on Short

**Trouble on Night Open** (Do not program for UL installations)

*Trouble on Open* will identify an open circuit on a loop as a trouble. *Trouble on Short* will identify a short circuit as a trouble. *Trouble on Night Open*, which will identify an open

circuit on a normally-closed zone while armed as a trouble condition (*not an alarm*), is intended for use with a Napco Monitor-Series dual-technology sensor. While there will be no indication at the keypad, any of these trouble conditions can be reported if *Report Trouble* is programmed as well. See *Sensor Watch*.

**Trouble/Trouble Restore Telco 1/Telco 3** See *Report Telco 1/Telco 3*

**Trouble/Trouble Restore Telco 2** See *Backup Report on Telco 2*

**Two-Digit Format** See *Data Format*

**Two-Wire Smoke Detectors** See *Smoke Detectors*

**User Codes/Authority Levels/Access Bytes**

**User Closing and Opening Reports by Telephone Numbers**

**Enable User Code by Area**

Up to 96 six-digit User Codes are programmable, each with its dedicated Authority Level and Access Byte. (The Authority Level comprises an Option Code.) Refer to Section 3: *User Codes, Authority Levels and Access Bytes* for instructions for programming from the keypad; also see the Keypad Programming Workbook WI641 for descriptions of levels and options.

If reporting to a central station, program *User Closing and Opening Reports by Telephone Numbers*. In multiple-area systems, program *Enable User Code by Area*.

**Watch Mode (by Area)** See *Day Zone*

**Waterflow**

**Auto-Reset Waterflow Zones**

A *Waterflow Zone* monitors sprinkler-system waterflow; it is activated by an initiating device approved for that purpose. An alarm on a *Waterflow Zone* will prevent the fire bell from being silenced or from timing out. The alarm can only be silenced if the [SILENCE] Button is pressed when the alarm condition no longer exists. If *Auto-Reset Waterflow Zones* is programmed, the *Waterflow Zone* will automat-

ically reset after the alarm condition is corrected. Also see *Time Selection*.

**Note:** A zone programmed as a *Waterflow Zone* must be programmed as a *Fire Zone* as well.

**Zone ANDing, Groups 1-8** (Do not program for UL installations)

**Enable Local Alarm on First Zone "AND" Trip** (Do not program for UL installations)

Up to eight groups of at least two zones each can be "AND"ed, wherein the system will go into alarm only if any two zones of the group are tripped within a prescribed time. This feature is designed to afford redundant protection for devices, such as glassbreak detectors, PIRs, etc., that may show a tendency to false under certain conditions. Program each group for any number of Zones 1-96. **Note:** Do not include a Panic Zone as part of any group.

If *Enable Local Alarm on First Zone "AND" Trip* is programmed, a trip on any zone of the group will cause an alarm indication at the keypad only; there will be no communication to the central station.

**Zone Area 1-Zone Area 8** See *Areas*

**Zone Number on Pulse Alarm** See *Data Formats: Two-Digit Format*

**Zone Type** See *Data Formats: Modem Formats*

**2-Wire, 4-Wire Smoke Detectors** See *Smoke Detectors*

**4-Wire Bus Failure** See *Bus-1 Failure; Bus-2 Failure*

**24-Hour Zone**

A zone that provides protection at all times, whether or not the system is armed. Neither the green STATUS nor the red ARMED LED will indicate the condition of a 24-Hour Zone, however an alarm condition will be recorded by the Alarm History Log after the [RESET] Button is pressed or the panel is armed, then disarmed.

**Note:** Do not program a Day Zone as a 24-Hour Zone.

## WIRING LEGEND

**INSTRUCTIONS:** Should removal of the circuit board be necessary, use this wiring legend to relocate leads to their proper terminals. Enter wire identification number or color code in WIRE NUMBER column; enter wire function in DESCRIPTION column (optional).

TERMINAL NO.	WIRE NO.	DESCRIPTION
1		
2		
3		
4		
5		
6		
7		
8		
9		
10		
11		
12		
13		
14		
15		
16		
17		
18		
19		
20		
21		
22		
23		
24		
25		
26		
27		
28		
29		
30		
31		
32		
33		
34		
35		
36		

**FOR SALES, SERVICE OR TECHNICAL ASSISTANCE, CALL TOLL FREE:**

**(800) 645-9445**

MAGNUM ALERT 3000 SYSTEM  
12-96 ZONES

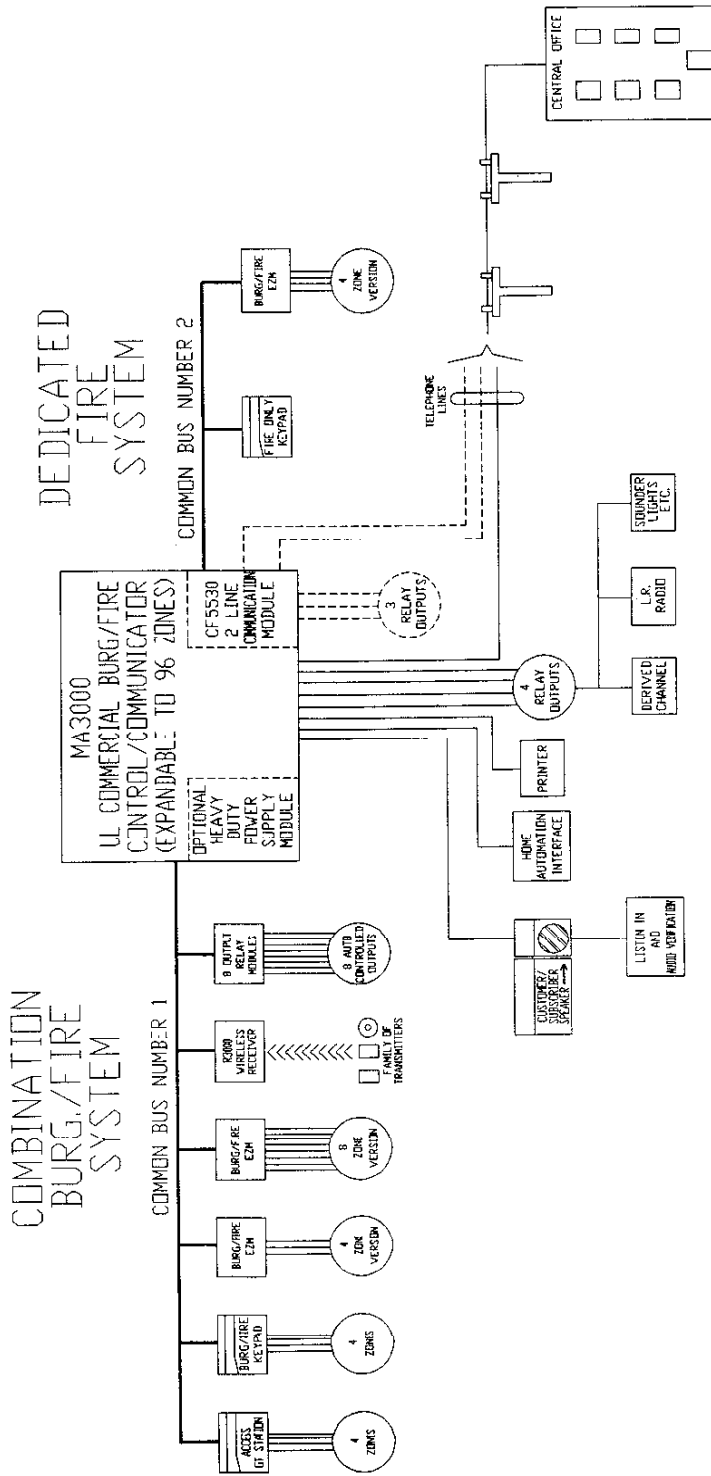

03663  
REV.C



# RP3000LCD KEYPAD FUNCTION AND PROGRAM MODES

NOTE: ONLY FUNCTIONS APPLICABLE TO USER'S AUTHORITY LEVEL ARE DISPLAYED; ALL OTHERS ARE SUPPRESSED.

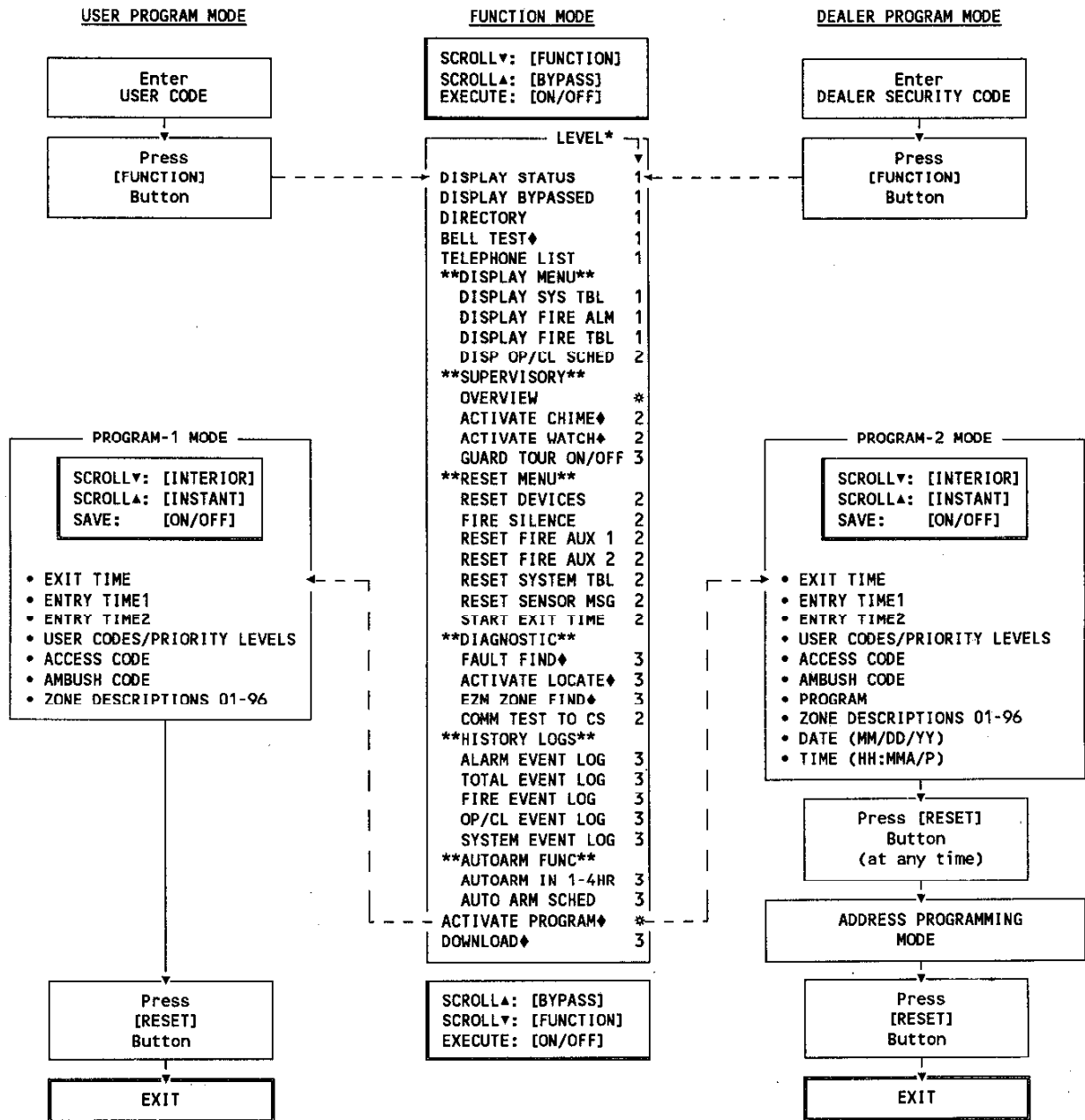

\*MINIMUM LEVEL REQUIRED TO ACCESS FUNCTION.  
 \*USER CODE OPTION (NOT LEVEL DEPENDENT).  
 ♦NOT AVAILABLE NOR DISPLAYED WHILE ARMED.



## FUNCTIONAL DIAGRAM, KEYPAD CONFIGURATION MODES

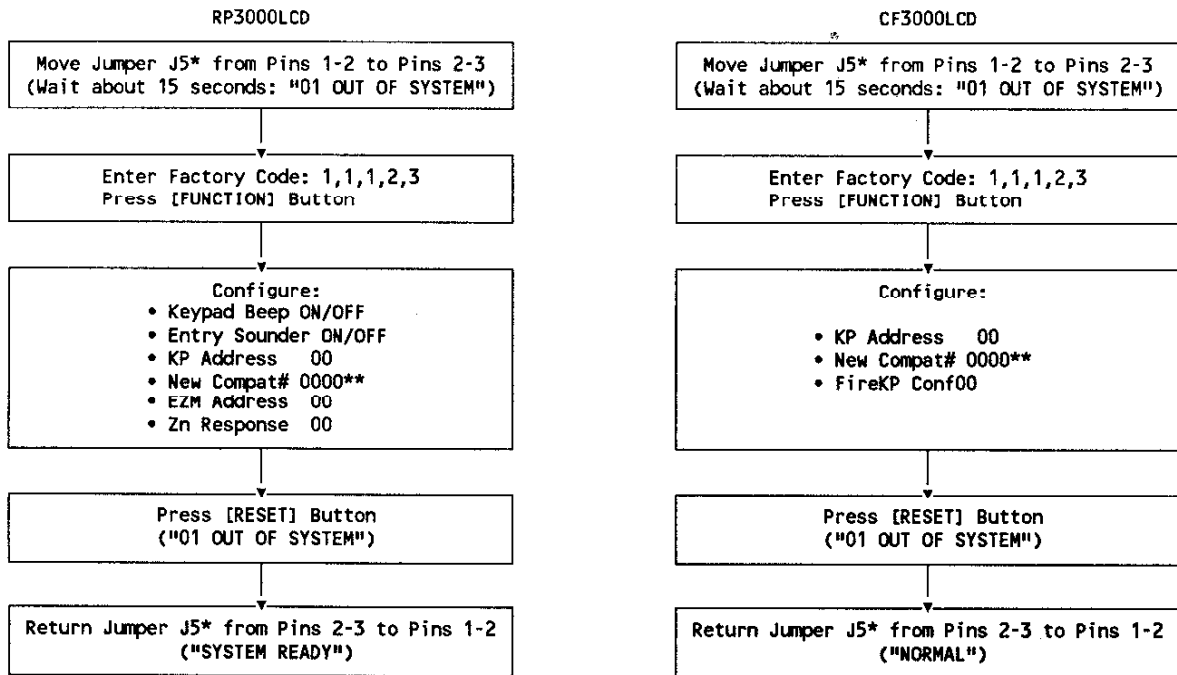

\*J5 is located to the left of the micro can.

\*\*If a Compatibility Number other than "0000" is programmed, "Old Compat. # xxxx" is displayed.

## RP3000LCD OPERATION, PROGRAM MODES

**NOTE:** In Commercial Fire installations, the control panel program may be viewed but not altered.

- Use [INTERIOR] & [INSTANT] Keys to select function to be programmed
- Use Keys [1] & [2] to place cursor.
- Use Keys [3] & [6] to change data (up and down, respectively).
- Press [ON/OFF] Key to save.

### Address Programming (From PROGRAM-2 MODE only)

- Use Keys [1] & [2] to place cursor.
- Use Keys [3] & [6] to change location; [\*] Key to read data; Keys [3] & [6] to change data.
- Use [ON/OFF] to save.

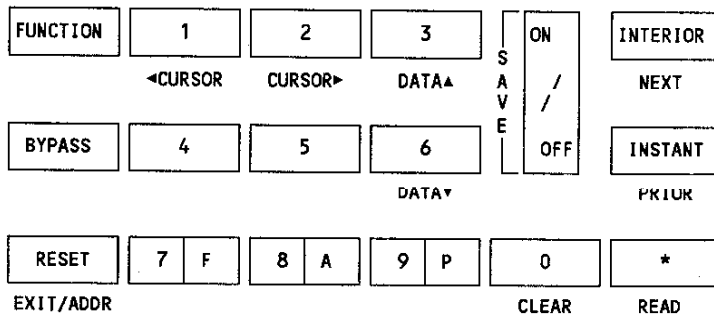
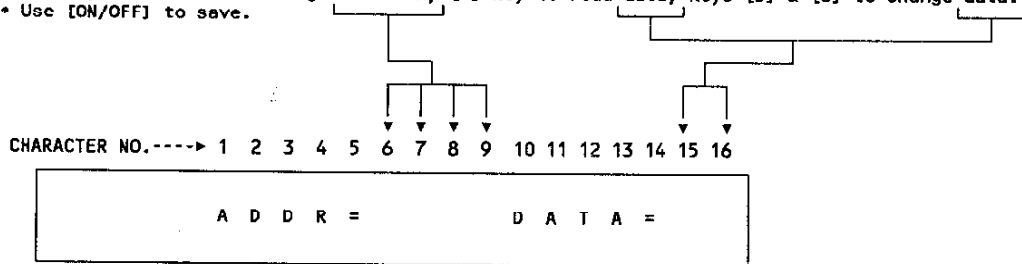

To Exit Address Program Mode, Press [RESET].

To Exit Program-1 or Program-2 Mode, Press [RESET].

## ENGLISH-LANGUAGE PROGRAM MODE (User Codes & Zone Descriptions)

### To Select User Code Number or Zone Number

- Use Keys [1] & [2] to place cursor over user number or zone number.
- Use Keys [3] & [6] to change user code number (U01-96) or zone number (01-96).
- Use Keys [1] & [2] to place cursor over code or zone description.
- Use Keys [3] & [6] to change user code or zone description.
  - User Codes require an accompanying Authority Level (\*\* = blank - no authority).
  - Zone Descriptions may consist of up to two lines.
- Press [SAVE] to store entry.
- Repeat for next code or zone description, or press [RESET] to exit.

## CF3000LCD OPERATION, PROGRAM MODES

NOTE: In Commercial Fire installations, the control-panel program may be viewed but not altered.

- Use [YES] & [NO] Keys to select function to be programmed
- Use Keys [1] & [2] to place cursor.
- Use Keys [3] & [6] to change data (up and down, respectively).
- Press [SILENCE] Key to save.

Address Programming (From PROGRAM-2 MODE only)

- Use Keys [1] & [2] to place cursor.
- Use Keys [3] & [6] to change location; [\*] Key to read data; Keys [3] & [6] to change data.
- Use [SILENCE] to save.

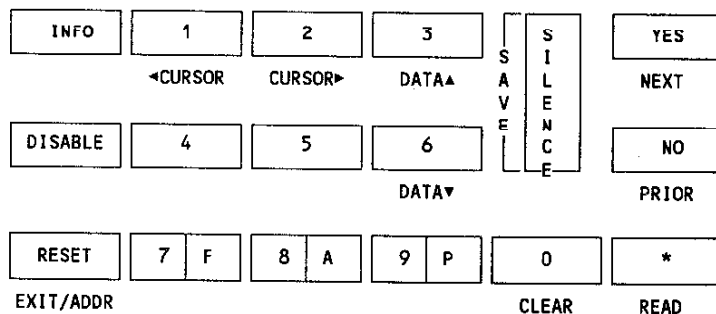
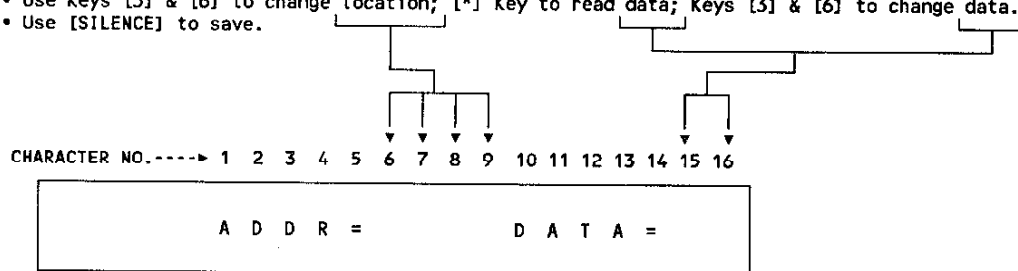

To Exit Address Program Mode, Press [RESET].

To Exit Program-1 or Program-2 Mode, Press [RESET].

### ENGLISH-LANGUAGE PROGRAM MODE (User Codes & Zone Descriptions)

To Select User Code Number or Zone Number

- Use Keys [1] & [2] to place cursor over user number or zone number.
- Use Keys [3] & [6] to change user code number (U01-96) or zone number (01-96).
- Use Keys [1] & [2] to place cursor over code or zone description.
- Use Keys [3] & [6] to change user code or zone description.
  - User Codes require an accompanying Authority Level (\*\* = blank - no authority).
  - Zone Descriptions may consist of up to two lines.
- Press [SILENCE] to store entry.
- Repeat for next code or zone description, or press [RESET] to exit.

## INDEX

A			
Abort Delay	23	Bell Cutoff with Waterflow Zone in Alarm	25
also see <i>Time Selection</i>	34-35	Bell Test	16
Ac Fail Report Delay	23	Block Diagram, System	39
also see <i>Time Selection</i>	34-35	Burglary Lug	25
Ac Failure	23	Burglary Relay, see <i>Alarm Outputs</i>	23
Access Byte	13	Rus-1 Failure	25
also see <i>User Codes/Authority Levels/Access Bytes</i>	36	Bus 2 Area	25
Access Control on Auxiliary Relay	23	Bus-2 Failure	25
Access Logging	23	Bypassing Zones	15
Access Number for Outside Line	23		
Access Only	23	C	
Activate Chime	16	Call Waiting, see <i>Disable Call Waiting</i>	28
Activate Locate	17	Callback Method Download	21, 25
Activate Program	18	Cancel Next Test Timer Report on Any Report, see	
Activate Watch	16	<i>Test Timer</i>	34
Address Programming	21, 42, 43	CF3000LCD Keypad	10, 12, 15, 43
Ademco Long-Range Wireless	9	Menu Mode	18
Alarm		Chime	25
Event Log	17	also see <i>Activate Chime</i>	16
Indication	15	Clear Program	25
Outputs	23	Closing Only on Force Arm	25
Alarm on Day Zone, see <i>Day Zone</i>	27	Closing Report	26
Alarm/Alarm Restore Telco 1/Telco 3, see <i>Report</i>		Commercial Fire	
<i>Telco 1/Telco 3</i>	32	Requirements	5, 8
Alarm/Alarm Restore Telco 2, see <i>Backup Report on</i>		Accessory Devices	5, 8
<i>Telco 2</i>	25	Programming	23
Ambush	24	Communicator,	
Code	13	Features	3
Answering Machine Pickup Without Line Seizure, see		Test	17
<i>Callback Method Download</i>	25	also see <i>Digital Dialer Test</i>	27
Anti-Jam Time	24	Compatibility Number	11, 12
Areas	24	Configuration,	
Arm Lug	24	Keypad	11-12, 41
Arming	13-14	Panel	10-11
Area Arming	14	System	12
With No Delay	14		
Authority Levels	13	D	
also see <i>User Codes/Authority Levels/Access Bytes</i>	36	Data Format	26
Autoarm		Day Zone	27
Function	18	Dealer Keypad Programming	21
Schedule	10	Dealer Security Code, see <i>Master Security Code</i>	31
Auto Bell Test on Arming	24	Default Program (Burglary)	27
Auto-Bypass	24	Diagnostic Menu	17
Auto Reset	24	Dial-Tone Detection	27
Auto Reset After Burglary Timeout	24	Digital Dialer Test	27
Auto Reset Waterflow Zones, see <i>Waterflow</i>	36	Directory	16, 18
Auxiliary Relay, see <i>Alarm Outputs</i>	23	Disable Answering Machine Download, see <i>Callback</i>	
Auxiliary Relay Access Control Time, see <i>Time Selection</i>	34-35	<i>Method Download</i>	25
		Disable Auto-Reset on Day Zone, see <i>Day Zone</i>	27
B		Disable Auto Status	28
Backup Report on Telco 2	25	Disable Call Waiting	28
Battery	25	Disable Callback Download, see <i>Callback Method</i>	
Bell Control	25	<i>Download</i>	25
		Disable Code Entry for Function Mode Level 1	28

Disable Function-Mode Download, see <i>Callback Method Download</i>	25	Features	3
Disarming	14	Fire	27
Display,		Drill	18
Bypassed	16	Event Log	17
Disabled Zones	18	Keypad, see <i>CF3000LCD</i>	
Fire Alarm	16, 19	Relay, see <i>Alarm Outputs</i>	23
Fire Log	18	Fire Area	29
Fire Trouble	16, 18	Fire Lug	29
Menu	16	Force Arm, see <i>Closing Report</i>	26
Opening/Closing Schedule	16	Function Mode (RP3000LCD)	15
Phone List	19	Function-Mode Download	21
Status	16	also see <i>Disable Function-Mode Download</i>	25
System Log	18		
System Trouble	16, 18	<b>G</b>	
Double Reporting, see <i>Report Telco 3</i>	32	Getting Up and Running	10
Download	18	Grounding	7
Callback Method	21, 25	Guard Tour	16
From a Computer	21		
Function Mode	21	<b>H</b>	
Local	21	History Log	17
Remote	21		
Download Security Code, see <i>Master Security Code</i>	31	<b>I</b>	
		Include Selective/Group Shunt in Force Arm/Status, see <i>Closing Report</i>	26
<b>E</b>		Installation	7
Easy Arming	28	Commercial Burglary	8
Easy Dypass	15, 33	Commercial Fire	8
also see <i>Enable Easy Bypass (Selective Bypass)</i>	33	Partitioned	8
Enable Brownout Limits on Ac Failure, see <i>Ac Failure</i>	23	Residential Fire	7
Enable Easy Bypass, see <i>Selective Bypass</i>	33	Interior Zones	15
Enable Entry Warning Bell Chirp	28	Interior Zones by Area	30
Enable Exit Delay Restart, see <i>Entry/Exit Delay</i>	29	Interior 1 Normally Bypassed	30
Enable Fire Reset	28		
Enable Ground-Fault Detection	28	<b>J</b>	
Enable Line-1 Fault Test	28	Jumpers	30
Enable Line-2 Fault Test	28		
Enable Local Alarm on First Zone "AND" Trip, see <i>Zone ANDing</i>	36	<b>K</b>	
Enable Reporting to PCD3000	28	Keypad	7, 10
Enable Second Phone Line	29	Address	11, 12
Enable User Code by Area, see <i>User Codes/Authority Levels/Access Bytes</i>	36	Area Change	14
Enable Watch, Area 1–8, see <i>Day Zone</i>	27	Assignments	10
Entry Sounder	11	Available Types	10
Entry/Exit Delay	29	Configuration	11–12, 41
Entry/Exit 1; Entry/Exit 2	29	Features	3
Exit/Entry Follower	29	Functions	40
Exit/Entry Times	12	Jumpers	30
Expansion Zones	29	Messages (RP3000LCD)	19
also see <i>Adding Expansion Zones</i>	7	Programming, Dealer	21, 42–43
Extended Format, see <i>Data Format</i>	26	Programming, User	12, 42–43
EZM Type	29	Programming Workbook	22
EZM PGM Armed Terminal Control	29	Tactile Beep	11
EZM Tamper, see <i>Tamper</i>	34	Wiring	7
EZM Zone Find	17	Keypad Area Assignments	30
		Keypad Aux Panic, see <i>Panic Zone</i>	31
<b>F</b>		Keypad Features	3, 30
Fault Find	17	Keypad Fire, see <i>Fire</i>	29
		Keypad Panic, see <i>Panic Zone</i>	31

Keypad Tamper, <i>see Tamper</i>	34
<b>L</b>	
Line Reversal Module, M278	30
List Directory	18
Loop Response	30
Low Battery	30
<b>M</b>	
Manager's Mode	14
Master Security Code	31
Memory Failure	31
Modem Formats, <i>see Data Format</i>	26
Mounting	7
<b>N</b>	
Never Arm	31
No EOL Resistor	31
Number of Rings Before Pickup, <i>see Callback-Method Download</i>	25
<b>O</b>	
One-Button Arming, <i>see Easy Arming</i>	28
Opening/Closing Event Log	17
Opening Report	31
Opening Report Only After Alarm Report	31
Optional Accessories	4
Overview Mode	14, 16
Ordering Information	4
<b>P</b>	
Pager Formats, <i>see Data Format</i>	26
Panel	
Access, <i>see Access Control on Auxiliary Relay</i>	23
Access Code	13
Configuration Sequence	10
Panic Zone	31
PCD3000 Quickloader Software 3, 8, 10, 13, 16, 18, 19, 21	
<i>also see Enable Reporting to PCD3000</i>	28
Power-Up Delay	31
Power-Up Sequence	10
Pre-Alarm Warning	31
Pre-Dial Delay	31
Printer Port	19
Priority Zone	32
Priority Zone with Bypass	32
Program Mode	19
Programming	21
Address	21, 42, 43
Dealer	21
Steps	22
User	12
User Codes	13
Workbook	22
Pulse Burglary Relay, <i>see Alarm Outputs</i>	23

<b>R</b>	
Receiver Format	32
Receivers, <i>see Data Format</i>	27
Relay Outputs, <i>see Alarm Outputs</i>	23
Remote Access, <i>see Access Control on Auxiliary Relay</i>	23
Access Code	13
Remote Relay Control	32
Report Telco 1	32
Report Telco 3	32
Reset	
Aux Fire 1/Aux Fire 2	18
Devices	17
Fire Aux 1/Aux 2	17
Fire Silence	17
Menu	17
Sensor Message	17
System Trouble	17
Zones (Fire)	18
Reset Day Zone with Arm/Disarm Only, <i>see Day Zone</i>	27
Reset Relay, <i>see Alarm Outputs</i>	23
RP3000LCD Keypad	10, 11, 15, 40, 42
<b>S</b>	
Security Bypass	15
Selective Bypass	33
Send Test Report	18
Sensor Watch	33
Service Code	13
Service Message	19
Silence Alarms	18
Single-Digit Format, <i>see Data Format</i>	26
Smoke Detectors	33
Compatible 2-Wire	5
Compatible 4-Wire	6
Specifications	
MA3000	4
CF5530 Communicator/Bell Module	4
PS3000 Power Supply	4
Split Reporting, <i>see Report Telco 3</i>	32
Sprinkler Supervisory	33
Start Exit Delay After Ringback	34
Start Exit Time	17
Status, <i>see Display Status</i>	16
Status Report, <i>see Closing Report</i>	26
Subscriber Identification Numbers	34
Sum Check Format, <i>see Data Format</i>	26
Supervisory Menu	16
Suppress "BYPASS" Reminder When Armed	34
Swinger Shutdown	34
System Event Log	17, 18
System Trouble,	
Display	16, 18
Silence	18
System Trouble Reports	34

**T**

Tamper	34
Switches	7
Telco Line Test Delay, see <i>Enable Line-1 Fault Test</i>	28
also see <i>Time Selection</i>	34-35
Telco-1 (-2) Fail, see <i>Enable Line-1 (-2) Fault Test</i>	28
Telephone List	16, 19
Telephone Numbers	34
Test Alarms	18
Test Timer	34
Testing the System	9
Timeout	34
Time Selection	34-35
Tour Station, see <i>Guard Tour</i>	16
Trouble	35
Trouble on Night Open	35
Trouble on Open	35
Trouble on Short	35
Trouble/Trouble Restore Telco 1/Telco 3, see <i>Report Telco 1/Telco 3</i>	32
Two-Digit Format, see <i>Data Format</i>	26

**U**

UL,	
Compatible Devices	5
Listings	5
Required Equipment	5
User Closing and Opening Reports by Telephone Numbers	36
User Codes/Authority Levels/Access Bytes	36
also see <i>User Codes</i>	13

User Keypad Programming	12
-------------------------	----

**W**

Watch Mode, see <i>Enable Watch, Area 1-8</i>	27
also see <i>Activate Watch</i>	16
Waterflow	36
Wiring	7
Wiring Diagram	39
Wiring Legend	37

**Z**

Zone ANDing, Groups 1-8	36
Zone Area 1-Zone Area 8, see <i>Areas</i>	24
Zone Descriptions	13, 42, 43
Zone Number on Pulse Alarm, see <i>Data Format</i>	26
Zones	
Bypassing	15
Fire, Disabling	15
Fire, Reset	18
Interior	15

1-Button Arming, see <i>Easy Arming</i>	28
2-Digit Format, see <i>Data Format</i>	26
2-Wire Smokes	5, 33
3/1 Format, see <i>Data Format</i>	26
4-Wire Bus Failure, see <i>Bus-1 (-2) Failure</i>	25
4-Wire Smokes	6, 33
4/2 Format, see <i>Data Format</i>	26
24-Hour Zone	36

## NAPCO LIMITED WARRANTY

**N**APCO SECURITY SYSTEMS, INC. (NAPCO) warrants its products to be free from manufacturing defects in materials and workmanship for fifteen months following the date of manufacture. NAPCO will, within said period, at its option, repair or replace any product failing to operate correctly without charge to the original purchaser or user.

This warranty shall not apply to any equipment, or any part thereof, which has been repaired by others, improperly installed, improperly used, abused, altered, damaged, subjected to acts of God, or on which any serial numbers have been altered, defaced or removed. Seller will not be responsible for any dismantling or reinstallation charges.

In case of defect, contact the security professional who installed and maintains your security system. NAPCO shall have no obligation under this warranty, or otherwise, if the product has been repaired by others, improperly installed, improperly used, abused, altered, damaged, subjected to accident, nuisance, flood, fire or acts of God, or on which any serial numbers have been altered, defaced or removed. NAPCO will not be responsible for any dismantling, reassembly or reinstallation charges.

In order to exercise the warranty, the product must be returned by the user or purchaser, shipping costs prepaid and insured to NAPCO. After repair or replacement, NAPCO assumes the cost of returning products under warranty.

*There are no warranties, express or implied, which extend beyond the description on the face hereof. There is no express or implied warranty of merchantability or a warranty of fitness for a particular purpose. Additionally, this warranty is in lieu of all other obligations or liabilities on the part of NAPCO.*

Any action for breach of warranty, including but not limited to any implied warranty of merchantability, must be brought within the six months following the end of the warranty period. In no case shall NAPCO be liable to anyone for any consequential or incidental damages for breach of this or any other warranty, express or implied, even if the loss or damage is caused by the seller's own negligence or fault.

*This warranty contains the entire warranty. It is the sole warranty and any prior agreements or representations, whether oral or written, are either merged herein or are expressly cancelled. NAPCO neither assumes, nor authorizes any other person purporting to act on its behalf to modify, to change, or to assume for it, any other warranty or liability concerning its products.*

In no event shall NAPCO be liable for an amount in

excess of NAPCO's original selling price of the product, for any loss or damage, whether direct, indirect, incidental, consequential, or otherwise arising out of any failure of the product. Seller's warranty, as hereinabove set forth, shall not be enlarged, diminished or affected by and no obligation or liability shall arise or grow out of Seller's rendering of technical advice or service in connection with Buyer's order of the goods furnished hereunder.

**NAPCO RECOMMENDS THAT THE ENTIRE SYSTEM BE COMPLETELY TESTED WEEKLY.**

**Warning:** Despite frequent testing, and due to, but not limited to, any or all of the following; criminal tampering, electrical or communications disruption, it is possible for the system to fail to perform as expected. NAPCO does not represent that the product/system may not be compromised or circumvented; or that the product or system will prevent any personal injury or property loss by burglary, robbery, fire or otherwise; nor that the product or system will in all cases provide adequate warning or protection. A properly installed and maintained alarm may only reduce risk of burglary, robbery, fire or otherwise but it is not insurance or a guarantee that these events will not occur. **CONSEQUENTLY, SELLER SHALL HAVE NO LIABILITY FOR ANY PERSONAL INJURY, PROPERTY DAMAGE, OR OTHER LOSS BASED ON A CLAIM THE PRODUCT FAILED TO GIVE WARNING.** Therefore, the installer should in turn advise the consumer to take any and all precautions for his or her safety including, but not limited to, fleeing the premises and calling police or fire department, in order to mitigate the possibilities of harm and/or damage.

NAPCO is not an insurer of either the property or safety of the user's family or employees, and limits its liability for any loss or damage including incidental or consequential damages to NAPCO's original selling price of the product regardless of the cause of such loss or damage. If the user wishes to protect itself to a greater extent, NAPCO will, at user's sole cost and expense, obtain an insurance policy to protect the user, supplemental to user's own policy, at a premium to be determined by NAPCO's insurer upon written notice from user by Certified Mail, Return Receipt Requested, to NAPCO's home office address, and upon payment of the annual premium cost by user.

Some states do not allow limitations on how long an implied Warranty lasts or do not allow the exclusion or limitation of incidental or consequential damages, or differentiate in their treatment of limitations of liability for ordinary or gross negligence, so the above limitations or exclusions may not apply to you. This Warranty gives you specific legal rights and you may also have other rights which vary from state to state.